

IOT Based Smart Home Energy Management System with Renewable Energy

S.AKASK, T.HARIHARAN, S.PURUSOTHAMAN

Department of Mechatronics Engineering, M.A.M School of Engineering, Chennai Trunk Road, Tiruchirappalli, Tamilnadu, India.

Department of Mechatronics Engineering, Faculty of M.A.M School of Engineering, Anna University, Chennai, Tamilnadu, India.

Corresponding authors : Dr. K. Vijayan., Associate Professor, Department of Mechanical Engineering, M.A.M School of Engineering, Trichy Tamilnadu, India

Abstract: Now energy management is a major issue of whole world. Due to our mistakes, lots of energy is lost. We always forgot to switch off light, fan and other appliances that consumes electricity. This Smart Energy Management System will detect the cause of energy loss in our home, residential building etc. Here temperature and light intensity sensor are used to sense the corresponding environmental aspects and automatically change light intensity and controls speed of the fan using an Arduino micro controller. LDR is used as light sensor and LM35 is the temperature sensor. The system also gives information about the amount of energy used and energy tariff. If we consume energy more than the given level the system will shut of energy flow by using a relay. Buzzer will give alarm to user if energy usage exceeds.

Key Words: LDR, Lm35, energy tariff, relay, Buzzer, Arduino

I. INTRODUCTION

Energy management systems have been in existence in the energy sector for several decades. The key functions of such systems are to watch, control, and optimize the flow and use of energy. In general, energy management systems have formidable applications in the generation, transmission and distribution systems of the electrical network. Today, the interests in Smart Energy Management systems have been increasing extensively. A smart energy management system is a technology platform comprised of both hardware and software that allows the user to monitor energy usage and production and to manually control and/or automate the utilization of energy within a household. Home energy management systems normally contains a tool which is the platform upon which communication between the user, the household appliances and devices and sometimes even the utility firm takes place. There are two main ways to put in the device; physically on the electrical board of the house or virtually especially in cases where the system operates entirely on a wireless network. The software used in smart energy management systems is responsible for the moderation of incoming and outgoing data and communication. For example, software, through the interface, allows users to possess access to the monitoring and controlling functions of the house energy monitoring system. Monitoring allows consumers to get various feedbacks from the system including which devices are turned on/off and even the individual energy consumption of specific devices. On the other hand, the control function allows users to control appliances. One other important component of the smart energy system is the network. Networks play a critical role in ensuring that different technologies are integrated into the house energy management system. Smart Home is a term that is widely used in order to define a living space with lighting, heating, air conditioner, TV, computer, entertainment, audio-visual systems, security and camera system that can communicate with each other. It is placed in the centre of our lives with regards to many areas like the TV, audio-visual system in our houses to run once we get home, lighting and electrical appliances can be operated remotely, and controlling the power consumption of such devices as refrigerator, air conditioner, furnace, etc. It may be impossible to control the home appliances outside the home. A user needn't turn on and OFF home appliances manually. Our system allows user to work through smart home energy management system. The energy consumed by the electrical appliances can be saved by at least 15% with the implementation of micro controller. It can be controlled via internet and the status of the working appliances can be calibrated through Blynk app. The proposed system has some advantages such as, anywhere it can be controlled, it is a low power consumption because micro controller power supply is only 20A.

II. EXISTING SYSTEM

Energy may be a vital aspect for any household, industries, agriculture then. Managing the energy efficiently and conserving it intelligently for appliances is very much important. The energy usage is directly affected with Coal, oil then towards power generation. Early EMS operations were based on analogue meters with skimpy, but fast, easy to understand information. They were however limited in scope and application. The application developed rapidly in the early 1970s. Most of the systems delivered before 1975 were supported Xeros Sigma 5 and Sigma 9. The technological evolutions in the 1980s further changed the EMS, particularly with the advent of personal computers. Software based system such as UNIX, LINUX and Windows-based systems added many possibilities to the EMS solutions in the early 2000s. Recent developments in embedded systems technological have further enhanced EMS functionalities. Many of the bulky, space-consuming solid-state technologies have given thanks to more compact, small and efficient embedded or chip-based systems. EMS also has age-long application within the residential sector. The use of workable night thermostat as a sort of automated energy control dates to the first 1900's. However, energy management became a true concern especially with the multiple energy crises, increasing cost and with the thought of energy conservation within the 1970's. Developing a functionally and customer-friendly EMS at residential level requires a relatively different approach from the existing EMS in the distribution and transmission networks. Honeywell developed a singular solar power managed system within the last 1970s supported microprocessor systems as a big contribution to solving energy crisis. Basically, HEMS offer five key services defined in, being monitoring, logging, control, management and alarms. Towards this, there has been lot of research work administered in developing some smart lighting system concerning classroom for conserving the energy. The smart energy management solutions can automate the facility status of electrical equipment. Almost 80% of the companies worldwide are overbilled on utility expenses through inconsistencies and wrongly calculated bills. . Using the smart energy solution, businesses also can know the electricity consumption per department. The systems provide business with an easy way to automatically analyses the power quality events. Also using sensors the system automatically switches off lights when not in use. The systems alert users in real-time when the light bulbs go out. The system uses a combination of technologies to enable data-driven lighting automation. Smart LED's can send information as well as receive commands in real-time which enable automation in them. Sensors sense changes in surroundings such as human presence and light. Software algorithms act as a brain which enables automation based on the sensor information and historical data.

III. PROPOSED SYSTEM

The major processing unit of the entire system is the Arduino unit, which is been connected to the various modules. The primary connection measures the current consumed by various devices. Further a connection is unified from this system to the relay and then further to other components like temperature sensor (LM 35), LDR, buzzer, LCD display (16*2).

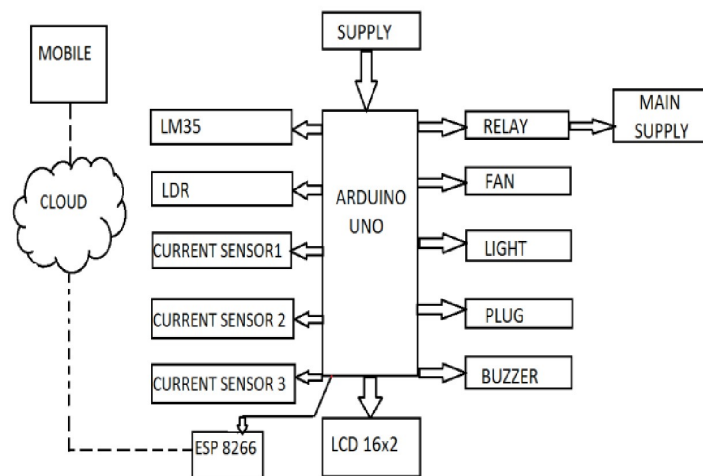

Fig 1: Block diagram of proposed system

The diagram of the whole project is shown above. Power from the AC mains is drawn and skilled a fuse for avoiding any damage to the circuit card during the accidental short .

Then the AC power cable is distributed in two parts:

1. To the load through the present sensor (ACS712)
2. 230V AC/5V DC Power Supply module

The 5V power supply module provides power to the micro controller (Arduino), the present sensor (ACS712) and LCD display. The present consumed by each appliance is measured with the assistance of a current sensor ACS712. The ACS712 Current Sensor may be a Hall Effect current sensor that accurately measures current when induced. The magnetic flux round the AC wire is detected which provides the equivalent analog output voltage. The analog voltage output is then processed by the micro controller to live the present flow through the load.

The AC current passing through the load is sensed by the current sensor module (ACS712) and fed to the analog pin (A0) of the Arduino board. Once the analog input is given to Arduino, the measurement of power/energy is completed by Arduino sketch.

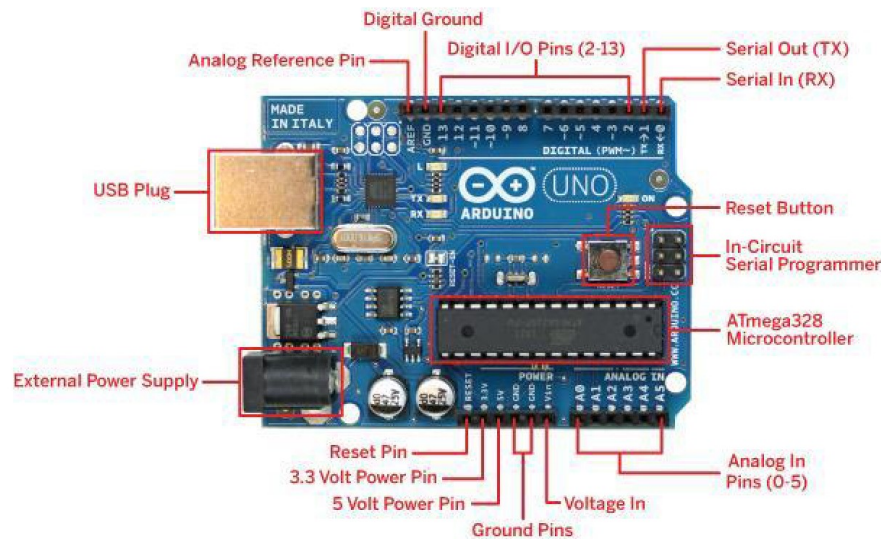

Fig 2: Arduino board

A 3 channel AC dimmer is used as an I/O device. This board is used in application where dimming of 110-220 V AC power is required, here it is used for dimming of light and fan.

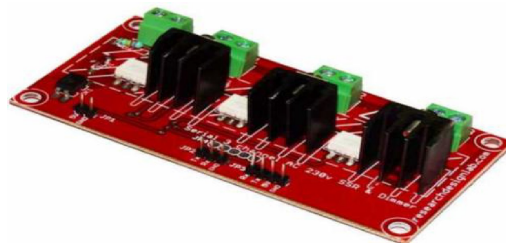

Fig 3: 3 Channel AC Dimmer

A temperature sensor (LM35) is used to measure the temperature and a light sensor is used to measure the intensity of light.

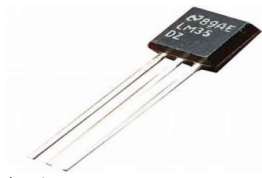

Fig 4: Temperature Sensor

Relays can control high voltage electronic devices. The electromagnet is activated with a low voltage, for example 5 volts from a micro controller and it pulls a contact to make or break a high voltage circuit. Several circuits can be controlled using relay.

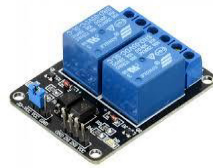
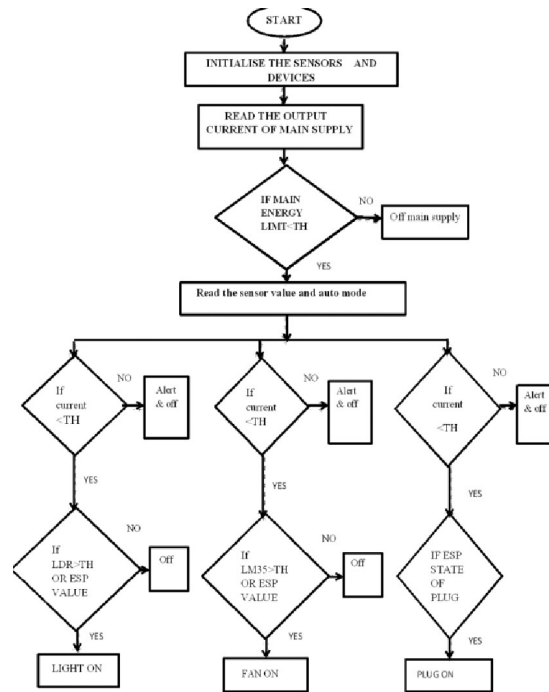

Fig 5: 2 Channel 5V Relay

The calculated power and energy by the Arduino are displayed on a 16x2 LCD display module. The inbuilt Wi-Fi chip of the Arduino UNO is connected to the Home Router and linked to the Blynk App. So, you can monitor the parameters as well as calibrate and modify different settings from your Smartphone via OTA.



IV.CONCLUSIONS

house is a private step toward the direction of renewable energy, environmental protection, and sustainable living. Having such a home helps homeowners reduce their bills and provides an excellent investment. Furthermore, energy efficiency means healthier and easier living that's in line with nature. Building or upgrading to an energy efficient home requires an initial investment that is higher than the cost of a traditionally constructed home. However, there are government grants and incentives which will help to urge you started and offset several the value. After you reside in your energy efficient house for a couple of years, your upfront investment can pay for itself.

REFERENCES

- [1] Phuangpornpitak, N. and Tia, S. (2013) Opportunities and Challenges of Integrating Renewable Energy in System. *Energy Procedia*, 34, 282-290. <https://doi.org/10.1016/j.egypro.2013.06.756>
- [2] Ullah, M. N., et al. "A Survey of Different Residential Energy Consumption Controlling Techniques for Autonomous DSM in Future Smart Grid Communications." arXiv preprint arXiv:1306.1134 (2013).
- [3] A. Kailas, V. Cecchi, and A. Mukherjee, Kailas, Aravind, ValentinaCecchi, and Arindam Mukherjee. "A survey of communications and networking technologies for energy management in buildings and home automation." *Journal of Computer Networks and Communications* 2012 (2012).
- [4] Fang, X., Misra, S., Xue, G. and Yang, D. (2012) Smart Grid—The New and Improved Power Grid: A Survey. *IEEE Communications Surveys & Tutorials*, 14, 944-980. <https://doi.org/10.1109/SURV.2011.101911.00087>
- [5] J. Li, J. Y. Chung, J. Xiao, J.W. Hong, and R. Boutaba, "On the design and implementation of a home energy management System," in *Proc. 6th Int. Symp. Wireless Pervasive Comput. (ISWPC)*, Feb. 23–25, 2011, pp. 1–6.
- [6] C.Nagarajan and M.Madheswaran - 'Experimental verification and stability state space analysis of CLL-T Series Parallel Resonant Converter' - *Journal of ELECTRICAL ENGINEERING*, Vol.63 (6), pp.365-372, Dec.2012.
- [7] C.Nagarajan and M.Madheswaran - 'Performance Analysis of LCL-T Resonant Converter with Fuzzy/PID Using State Space Analysis' - *Springer, Electrical Engineering*, Vol.93 (3), pp.167-178, September 2011.
- [8] C.Nagarajan and M.Madheswaran - 'Stability Analysis of Series Parallel Resonant Converter with Fuzzy Logic Controller Using State Space Techniques' - *Taylor & Francis, Electric Power Components and Systems*, Vol.39 (8), pp.780-793, May 2011.
- [9] C.Nagarajan and M.Madheswaran - 'Experimental Study and steady state stability analysis of CLL-T Series Parallel Resonant Converter with Fuzzy controller using State Space Analysis' - *Iranian Journal of Electrical & Electronic Engineering*, Vol.8 (3), pp.259-267, September 2012.
- [10] Nagarajan C., Neelakrishnan G., Akila P., Fathima U., Sneha S. "Performance Analysis and Implementation of 89C51 Controller Based Solar Tracking System with Boost Converter" *Journal of VLSI Design Tools & Technology*. 2022; 12(2): 34–41p.
- [11] C. Nagarajan, G.Neelakrishnan, R. Janani, S.Maithili, G. Ramya "Investigation on Fault Analysis for Power Transformers Using Adaptive Differential Relay" *Asian Journal of Electrical Science*, Vol.11 No.1, pp: 1-8, 2022.
- [12] G.Neelakrishnan, K.Anandhakumar, A.Prathap, S.Prakash "Performance Estimation of cascaded h-bridge MLI for HEV using SVPWM" *Suraj Punj Journal for Multidisciplinary Research*, 2021, Volume 11, Issue 4, pp:750-756
- [13] G.Neelakrishnan, S.N.Pruthika, P.T.Shalini, S.Soniya, "Perfromance Investigation of T-Source Inverter fed with Solar Cell" *Suraj Punj Journal for Multidisciplinary Research*, 2021, Volume 11, Issue 4, pp:744-749
- [14] C.Nagarajan and M.Madheswaran, "Analysis and Simulation of LCL Series Resonant Full Bridge Converter Using PWM Technique with Load Independent Operation" has been presented in *ICTES'08*, a IEEE / IET International Conference organized by M.G.R.University, Chennai.Vol.no.1, pp.190-195, Dec.2007
- [15] M Suganthi, N Ramesh, "Treatment of water using natural zeolite as membrane filter", *Journal of Environmental Protection and Ecology*, Volume 23, Issue 2, pp: 520-530,2022
- [16] M Suganthi, N Ramesh, CT Sivakumar, K Vidhya, "Physiochemical Analysis of Ground Water used for Domestic needs in the Area of Perundurai in Erode District", *International Research Journal of Multidisciplinary Technovation*, pp: 630-635, 2019
- [17] J. Han, C. S. Choi, W. K. Park, and I. Lee, "Green home energy management system through comparison of energy usage between the same kinds of home appliances," in *Proc. 15th IEEE Int. Symp. Consum. Electron. (ISCE)*, 2011, pp. 1–4.
- [18] M. Erol-Kantarci and H. T. Mouftah, "Wireless sensor networks for cost efficient residential energy management in the smart grid," *IEEE Trans. Smart Grid*, vol. 2, no. 2, pp. 314–325, 2011.
- [19] M. A. A. Pedrasa, T. D. Spooner, and I. F. MacGill, "Coordinated scheduling of residential distributed energy resources to optimize smart home energy services," *IEEE Trans. Smart Grid*, vol. 1, no. 2, pp. 134–143, Sep. 2010.
- [20] Martiskainen, M. and Coburn, J. (2010) The Role of Information and Communication Technologies (ICTs) in Household Energy Consumption/Prospects for the UK. *Energy Efficiency*, 4, 209-221. <https://doi.org/10.1007/s12053-010-9094-2>
- [21] Zhou, W., Lou, C., Li, Z., Lu, L. and Yang, H. (2010) Current Status of Research on Optimum Sizing of Stand-Alone Hybrid Solar-Wind Power Generation Systems. *Applied Energy*, 87, 380-389. <https://doi.org/10.1016/j.apenergy.2009.08.012>
- [22] Evans, A., Strezov, V. and Evans, T.J. (2009) Assessment of Sustainability Indicators for Renewable Energy Technologies. *Renewable and Sustainable Energy Reviews*, 13, 1082-108. <https://doi.org/10.1016/j.rser.2008.03.008>
- [23] Hepbasli, A. (2008) A Key Review on Exergetic Analysis and Assessment of Renewable Energy Resources for a Sustainable Future. *Renewable and Sustainable Energy Reviews*, 12, 593-661. <https://doi.org/10.1016/j.rser.2006.10.001>