

Automatic Railway Gate Opening and Alerting System

¹S. Ramya, ²B. Tharani, D. Kathirvel, ³R. Rakul, ⁴S. Sanjay krishna, ⁵V. Vidyakar
¹Assistant Professor, ²Associate Professor, ^{3,4,5}Students / Electrical and Electronics Engineering,
Sri Shakthi Institute of Engineering and Technology, Coimbatore, India

Abstract— The Automatic Railway Gate Opening and Alerting System is a sophisticated solution designed to enhance the safety and efficiency of railway crossings. This system employs a combination of advanced technologies, including sensors, microcontrollers, and communication modules, to automate the operation of railway gates and provide timely alerts to ensure the safety of both pedestrians and vehicles. The system utilizes infrared sensors to detect the presence of approaching trains from a considerable distance. These sensors continuously monitor the railway tracks and, upon detection of an approaching train, send signals to the microcontroller unit. The microcontroller processes the incoming signals and triggers the automatic opening or closing of the railway gates based on the train's proximity.

Keywords-automation; enhance-safety; efficiency; sensors, communication module, timely alerts, monitoring.

I. INTRODUCTION

The Automatic Railway Gate Opening and Alerting System is a comprehensive safety solution designed to streamline the operation of railway crossings while prioritizing safety. This system relies on a network of sensors strategically placed near the railway tracks and on the approaching roads. Train detection sensors identify the presence of an incoming train, while vehicle and pedestrian sensors detect traffic on the road. A central microcontroller processes information from these sensors and activates gate actuators to open or close the railway gates accordingly. Communication modules transmit crucial information about the crossing status to central control systems or nearby stations, fostering coordination across the railway network. An integrated alerting system warns road users and pedestrians of an approaching train and the subsequent gate closure through lights, sirens, or other signals. The inclusion of an emergency override ensures manual control in unforeseen circumstances. Overall, this system not only enhances safety by minimizing the risk of accidents but also contributes to the efficiency of railway operations, particularly at unmanned or remote crossings. Furthermore, the Automatic Railway Gate Opening and Alerting System incorporates a reliable power supply mechanism, essential for continuous and uninterrupted operation. Depending on the specific location, a combination of mains power and backup solutions such as batteries or generators is employed to ensure the system's resilience. The technology also integrates seamlessly with existing railway signaling systems, ensuring synchronization with train schedules and preventing gate openings at inappropriate times. The implementation of this system is particularly crucial at unmanned or remote railway crossings, where the absence of constant human monitoring necessitates the reliability and autonomy of automated mechanisms. By automating the gate control process, this system not only reduces the likelihood of accidents involving vehicles and pedestrians but also contributes to the overall efficiency of railway transportation, aligning with modern safety standards and technological advancements in the railway industry. Most of the railway gate opening and closing systems are operated manually so to rectify this process this automated system is created. This ensures that the gates are in the appropriate position to prevent accidents and collisions. Additionally, this System incorporates a real-time communication module to disseminate timely alerts to nearby road users and pedestrians. The system sends alerts via SMS (Short Message Service) or other communication channels, informing individuals in the vicinity about the approaching train and the status of the railway gates. This proactive alert mechanism enhances public safety by providing ample time for road users to clear the railway crossing area, preventing any potential accidents.

The proposed system aims to overcome the limitations of traditional manual railway gate operation, which is prone to human errors, delays, and lacks an effective alerting mechanism. This system is designed to be scalable, adaptable, and compatible with existing railway infrastructure, making it a viable solution for improving railway safety and mitigating the risks associated with level crossings.

II. PROBLEM DESCRIPTION

The implementation of Automatic Railway Gate Opening and Alerting Systems introduces potential challenges. First, the reliability of sensors, including train and traffic detectors, poses concerns due to environmental factors like adverse weather. Power supply issues, especially in remote areas, may lead to system failures, necessitating robust backup solutions. Integrating these systems with existing railway infrastructure can

be complex, requiring careful coordination to synchronize operations. Maintenance challenges, driven by exposure to harsh conditions, demand a proactive schedule to prevent wear and tear. The effectiveness of emergency response and manual override mechanisms is critical in unforeseen situations. The initial costs, including installation and ongoing maintenance, represent a significant financial investment. Security considerations must address potential vulnerabilities in communication channels and control systems. Lastly, public awareness and education programs are essential to ensure the safe and compliant use of the automated gate system by drivers and pedestrians alike.

III. PROPOSED SYSTEM

The proposed Automatic Railway Gate Opening and Alerting System represents a comprehensive solution aimed at enhancing safety and efficiency in railway operations. Leveraging a network of sensors including proximity sensors, photoelectric sensors, and speed sensors, the system continuously monitors the railway track and its surroundings, detecting the presence of approaching trains and potential obstacles. Through sophisticated data processing algorithms running on a centralized Microcontroller Unit (MCU), the system intelligently analyzes sensor inputs to make informed decisions regarding gate operations. Actuators such as gate motors and alarm systems are then seamlessly controlled to ensure timely opening and closing of railway gates, thereby safeguarding against collisions and accidents. Moreover, the integration of a communication module enables real-time alerts and notifications to be disseminated to relevant stakeholders, ensuring swift response to emergencies or system malfunctions. By incorporating safety features such as redundancy and fail-safe mechanisms, along with the utilization of renewable energy sources for power supply, the system not only enhances safety but also promotes sustainability and operational efficiency in railway management. Overall, the Automatic Railway Gate Opening and Alerting System serves as a critical asset in modernizing railway infrastructure, facilitating safer and smoother transportation for passengers and cargo alike.

ADVANTAGES OF PROPOSED SYSTEM

Enhanced Safety: The automated system minimizes the risk of accidents at railway crossings by ensuring timely gate closure and alerting mechanisms, reducing the likelihood of collisions between trains, vehicles, and pedestrians.

Efficiency Improvement: The automation of gate operations streamlines the flow of both rail and road traffic, contributing to the overall efficiency of railway transportation.

Reduced Human Error: Automation reduces the reliance on human operators for gate control, minimizing the potential for errors and oversights that can lead to unsafe situations.

Timely Response: The system provides prompt detection of approaching trains and traffic, allowing for quick response times in activating gate closure mechanisms and alerting systems.

Integration with Signaling Systems: Integration with existing railway signaling systems ensures synchronized operations, preventing conflicts between train schedules and gate openings.

Continuous Monitoring: Automated systems enable continuous monitoring of the railway crossing, ensuring that gates respond to real-time conditions and contributing to a proactive approach to safety.

Adaptability: The system can be designed to adapt to various environmental conditions, making it suitable for deployment in diverse geographical locations and climates.

Cost-Effective Maintenance: While initial setup costs may be significant, automated systems often result in long-term cost savings by reducing the need for constant manual oversight and maintenance.

Emergency Override Capability: The inclusion of an emergency override mechanism allows for manual control in exceptional situations, ensuring flexibility and responsiveness in emergencies.

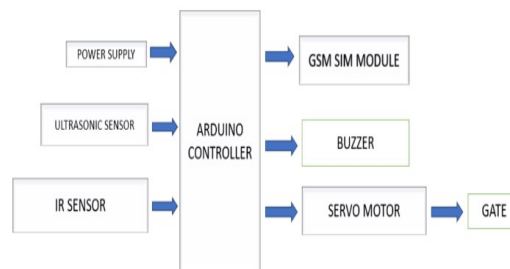

Figure 1. Block diagram Block diagram

The main component Arduino uno is connected to a proper power supply, the input signal components such as ultrasonic sensor, ir sensor sends the signal to the arduino controller when the train passes the sensors on the marked parameters. When the signals are received by the Arduino from the sensors the Arduino sends signal

and power supply to the components such as buzzer, servo motors and the gsm module. The gsm then later informs the control station and the local nearby station about the status of the gate being closed or open. Shortly the Arduino connected to supply, Arduino takes input signals from ir and ultrasonic sensors then after the signal is received the Arduino sends output signal to the servo, buzzer and gsm module.

CIRCUIT DIAGRAM

In the power supply system 230V AC is converted into 5V DC which is required for Arduino microcontroller, IR Sensor, Servo motor, GSM SIM module. We have been used Arduino microcontroller at starting it will Alert to the given number and then it assigns the input and output pin configuration then it checks the gate is open or closed. Then the IR sensor sense the train. In this case, if the gate is not closed alert to station master. All the values of the sensors will be sent to Arduino platform. In this, it uses serial communication protocol. Using this we can be monitored them

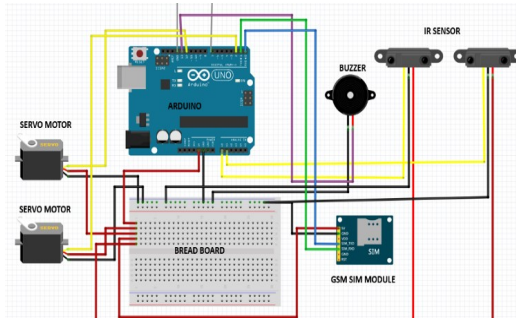

Figure 2. Circuit diagram

HARDWARE DESCRIPTION

ARDUINO MICROCONTROLLER

The Arduino Uno is an open-source microcontroller board based on the Microchip ATmega328P microcontroller (MCU) and developed by Arduino.cc and initially released in 2010.[2][3] The microcontroller board is equipped with sets of digital and analog input/output (I/O) pins that may be interfaced to various expansion boards (shields) and other circuits.[1] The board has 14 digital I/O pins (six capable of PWM output), 6 analog I/O pins, and is programmable with the Arduino IDE (Integrated Development Environment), via a type B USB cable.[4] It can be powered by a USB cable or a barrel connector that accepts voltages between 7 and 20 volts, such as a rectangular 9-volt battery. It has the same microcontroller as the Arduino Nano board, and the same headers as the Leonardo board. The hardware reference design is distributed under a Creative Commons Attribution Share-Alike 2.5 license and is available on the Arduino website. Layout and production files for some versions of the hardware are also available.

Pin layout of the Arduino Uno board

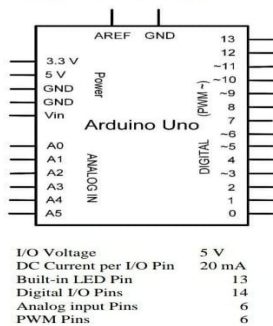

Figure 3. Arduino uno microcontroller

INPUT/OUTPUT PROGRAMMING

General purpose I/O pins can be considered the simplest of peripherals. They allow the PIC microcontroller to monitor and control other devices. To add flexibility and functionality to a device, some pins are multiplexed with an alternate function(s). These functions depend on which peripheral features are on the device. In general, when a peripheral is functioning, that pin may not be used as a general purpose I/O pin. For most ports, the I/O pin's direction (input or output) is controlled by the data direction register, called the TRIS register. TRIS<x> controls the direction of PORT<x>. A '1' in the TRIS bit corresponds to that pin being an input, while a '0' corresponds to that pin being an output. An easy way to remember is that a '1' looks like I (input) and a '0' looks like an O output). The PORT register is the latch for the data to be output. When the PORT is read, the device reads the levels present on the I/O pins (not the latch). This means that care should be taken with read-modify-write commands on the ports and changing the direction of a pin from an input to an output. The TRIS

registers control the direction of the port pins, even when they are being used as analog inputs. The user must ensure the TRIS bits are maintained set when using the pins as analog inputs.

1. HARDWARE IMPLEMENTATION

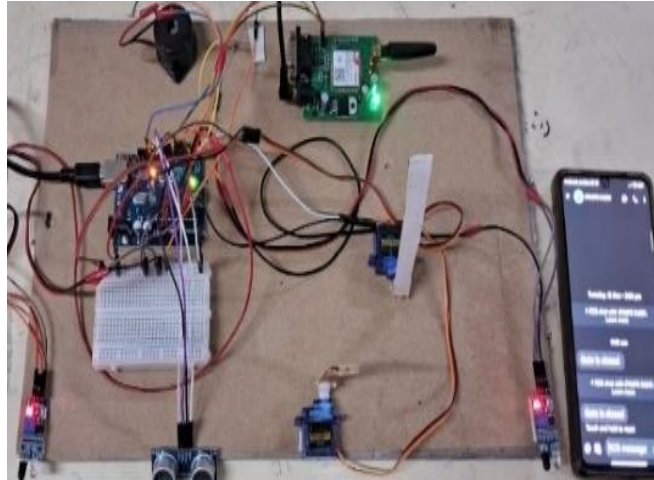

Figure 4. Hardware implementation

The above fig.4 is the final hardware assembling of the automatic railway gate opening system. The components such as ir sensors, ultrasonic sensor, servo motor, gsm module, buzzer are connected to the Arduino microcontroller. The breadboard is used to give power supply for all the components

Which is DC 5v power supply. The ir sensors are the first component to detect the approaching train and which it sends the information to the Arduino uno microcontroller and the microcontroller give passes the signal to the gates which is servo motors and commands it to close and the status of the gate is sent to the nearest station and the local members. If the close isn't closed then it triggers the gsm module and the module alerts the station and locals.

IV.CONCLUSION

In conclusion, the Automatic Railway Gate Opening and Alerting System stands as a transformative solution in enhancing the safety and efficiency of railway crossings. By automating gate operations and integrating advanced sensors and communication modules, the system significantly reduces the risk of accidents at these critical intersections. The advantages, including improved safety, reduced human error, and increased efficiency, underscore its potential to revolutionize railway transportation. While challenges such as sensor reliability and integration complexities exist, addressing these issues through meticulous planning and technology refinement will contribute to the system's overall success. With continuous monitoring, adaptability to various conditions, and an emergency override mechanism, this automated system aligns with modern safety standards. Through a combination of technological innovation and public awareness initiatives, the Automatic Railway Gate Opening and Alerting System emerges as a pivotal step toward creating a safer and more streamlined railway environment for both rail and road users.

REFERENCES

- [1] S Surya;P Kausik;G Diyaneshwaran;R Raffik 2023 2nd International Conference on Advancements in Electrical, Electronics, Communication, Computing and Automation (ICAECA) "Railway Gate Automation using Onboard Computing Techniques"
- [2] Taslim Ahmed;Imran Chowdhury 2020 IEEE International Conference on Electronics, Computing and Communication Technologies (CONECT) 'Into the binary World of Zero death toll by Implementing a Sustainable Powered Automatic Railway Gate Control system'
- [3] C.Nagarajan and M.Madheswaran - 'Experimental verification and stability state space analysis of CLL-T Series Parallel Resonant Converter' - Journal of ELECTRICAL ENGINEERING, Vol.63 (6), pp.365-372, Dec.2012.
- [4] C.Nagarajan and M.Madheswaran - 'Performance Analysis of LCL-T Resonant Converter with Fuzzy/PID Using State Space Analysis'- Springer, Electrical Engineering, Vol.93 (3), pp.167-178, September 2011.
- [5] C.Nagarajan and M.Madheswaran - 'Stability Analysis of Series Parallel Resonant Converter with Fuzzy Logic Controller Using State Space Techniques'- Taylor & Francis, Electric Power Components and Systems, Vol.39 (8), pp.780-793, May 2011.
- [6] C.Nagarajan and M.Madheswaran - 'Experimental Study and steady state stability analysis of CLL-T Series Parallel Resonant Converter with Fuzzy controller using State Space Analysis'- Iranian Journal of Electrical & Electronic Engineering, Vol.8 (3),pp.259-267, September 2012.
- [7] Nagarajan C., Neelakrishnan G., Akila P., Fathima U., Sneha S. "Performance Analysis and Implementation of 89C51 Controller Based Solar Tracking System with Boost Converter" Journal of VLSI Design Tools & Technology. 2022; 12(2): 34-41p.

- [8] C. Nagarajan, G.Neelakrishnan, R. Janani, S.Maithili, G. Ramya “Investigation on Fault Analysis for Power Transformers Using Adaptive Differential Relay” Asian Journal of Electrical Science, Vol.11 No.1, pp: 1-8, 2022.
- [9] G.Neelakrishnan, K.Anandhakumar, A.Prathap, S.Prakash “Performance Estimation of cascaded h-bridge MLI for HEV using SVPWM” Suraj Punj Journal for Multidisciplinary Research, 2021, Volume 11, Issue 4, pp:750-756
- [10] G.Neelakrishnan, S.N.Pruthika, P.T.Shalini, S.Soniya, “Perfromance Investigation of T-Source Inverter fed with Solar Cell” Suraj Punj Journal for Multidisciplinary Research, 2021, Volume 11, Issue 4, pp:744-749
- [11] C.Nagarajan and M.Madheswaran, “Analysis and Simulation of LCL Series Resonant Full Bridge Converter Using PWM Technique with Load Independent Operation” has been presented in ICTES’08, a IEEE / IET International Conference organized by M.G.R.University, Chennai.Vol.no.1, pp.190-195, Dec.2007
- [12] M Suganthi, N Ramesh, “Treatment of water using natural zeolite as membrane filter”, Journal of Environmental Protection and Ecology, Volume 23, Issue 2, pp: 520-530,2022
- [13] M Suganthi, N Ramesh, CT Sivakumar, K Vidhya, “Physiochemical Analysis of Ground Water used for Domestic needs in the Area of Perundurai in Erode District”, International Research Journal of Multidisciplinary Technovation, pp: 630-635, 2019
- [14] Gauransh Singh;Praveen Kumar;Rishabh Kumar Mishra;Sanskriti Sharma;Kushagra Singh 2nd International Conference on Advances in Computing, Communication Control and Networking (ICACCCN) ‘Security system for Railway Crossings using machine learning’
- [15] Shankha Banerjee;Sayan Mondal;Amartya Chakraborty;Suvendu Chattaraj 2020 International Conference on Computer, Electrical & Communication Engineering (ICCECE) ‘Global Positioning system based on automated Railway Level Crossings’
- [16] Bernard Adaramola;Adedotun Adetunla;Joseph Kayode;Chigozie Okoronkwo 2023 International Conference on Science, Engineering and Business for Sustainable Development Goals (SEB-SDG) “ Design and Fabrication of Prototype Automated Railway Gate Controller”
- [17] Vedasingha K.S;Perera K. K. M. T.;Hathurusinghe K. I.;Akalanka H. W. I.;Nelum Amarasena;Nalaka R. Dissanayake 2021 3rd International Conference on Advancements in Computing (ICAC) ‘Enhance the safety Measurements with the Aid of Iot and Image Processing’
- [18] Puja Bhowmik;Shoriful Islam;Jariatullah Khanam Sifat;M d.Shihab Mahmud;Fahad Faisal 2022 6th International Conference on Trends in Electronics and Informatics (ICOEI) ‘Design and Development of Iot based automated railway level crossing’