

Single Switch PWM Converter Fed PMDC Motor

Dr C.Nagarajan,
*Head of Department,
Department of EEE,
Muthayammal College of Engineering, Rasipuram.*

Mr.G.Neelakrishnan,
*Assistant professor,
Department of EEE,
Muthayammal College of Engineering, Rasipuram.*

C.Dhanalakshmi,
*Student, Department of EEE,
Muthayammal College of Engineering, Rasipuram.*

B.Nithishree,
*Student, Department of EEE,
Muthayammal College of Engineering, Rasipuram.*

S.Ramya,
*Student, Department of EEE,
Muthayammal College of Engineering, Rasipuram.*

Abstract- The main focus is on new power converter topologies that convert a three phase AC input voltage into an isolated DC output voltage with a reduced number of switches for speed controlling PMDC motor. In the thesis, a new family of reduced switch front-end converter topologies is proposed, an example converter from this new family is selected for further study and a modified version of this topology is studied as well. The properties and characteristics of three-phase AC-DC single-switch converter is analyzed using MATLAB/Simulink software. For each new converter that is investigated in detail, its modes of operation are explained, its steady-state characteristics are determined.

Index terms -Single Switch AC-DC Conversion, PMDC Motor.

I. INTRODUCTION

Power electronic converters use active semiconductors (e.g. IGBTs) and passive power semiconductors (e.g. diodes) and passive elements (e.g. inductors and capacitors) arranged in circuit structures to convert power from the form available from a source to that required by a load. The power source may be a DC source, a single-phase AC source, or a three-phase AC source with line frequency of 50, 60 or 400 Hz. It may also be an electric battery, a solar panel, an electric generator or a commercial power supply. The source feeds the input of the power converter, which converts the input power to the required form for a load. The load may be DC or AC, single-phase or three-phase, and may or may not need transformer isolation from the power source. The power converter, therefore, can be an AC/DC converter, a DC/DC converter, a DC/AC inverter or an AC/AC converter depending on the application. The main focus of the research in this thesis has been on three-phase AC-DC power converters. These are converters that convert a three-phase input voltage into an isolated DC output voltage. The three-phase AC voltage is typically obtained from the utility mains. AC-DC power converters connected to the mains voltage can generate and inject current harmonics into the utility mains [2]-[3]. Injecting current harmonics into the AC mains results in two significant consequences: First, because of the finite impedances of the power lines, harmonic currents generate voltage variations at the point of common coupling that other equipment on the line must tolerate. Second, although current harmonics do not generate real power, they must be considered in the design of power lines so that power lines must be significantly overrated lest they overheat. As a result, regulatory bodies have imposed strict

limits on the harmonics that power converter can inject into the utility mains. To minimize the harmonics generated by power converters, power factor that can be achieved and represents the most efficient use of the input AC source. AC-DC power converters implemented with PFC techniques are made to operate in such a way that their input currents are shaped so that they are sinusoidal and in phase with their respective phase voltages. Most AC-DC power converters today that are supplied by the AC mains are implemented with some sort of PFC technique and the implementation of PFC in power electronic converters is a very relevant research topic in the power electronics field.[2]-[5]. Three-phase ac-dc converters usually have two separate and

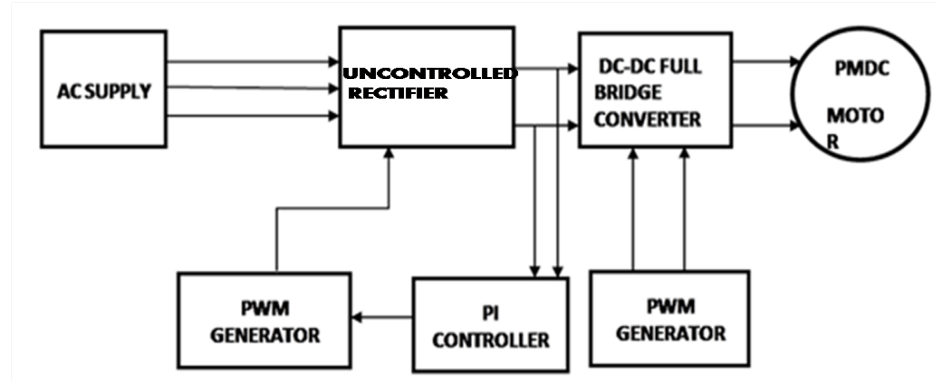

Fig 1. Single-Stage AC-DC PWM Full-Bridge Converter for PMDC Motor

Independently controlled switch-mode power converters—a six-switch ac-dc rectifier that performs input power factor correction (PFC) in series with a four-switch transformer-isolated dc-dc full-bridge converter. AC-DC converters with simplified front-end converters, however, still require two separate switch mode converters. The previously proposed three-phase single-switch converters have a boost converter input section. These converters suffer from high input ripple as their input currents are discontinuous with high current peaks, high output ripple and a large low-frequency component at the output due to a lack of a capacitor [1]. Here a three phase single switch ac-dc converter is used. Converters that are based on buck converters do not have high input and output ripple as they have inductive-capacitive filtering in their input and output sections and can be implemented with a bulk capacitor at their dc bus. The fundamental principle behind its ability to perform PFC is that the voltage across the input capacitors is discontinuous. The waveform is a discontinuous waveform that is bounded by a sinusoidal envelope so that it is essentially sinusoidal with high-frequency harmonics. If the input capacitor voltages are not sinusoidal, then they will contain low-frequency harmonics, and so too will the voltage across each input inductor. This will create low-frequency harmonics in the input currents as the input inductor voltages have the same

II. BLOCK DIAGRAM DESCRIPTION

In the fig.1 the permanent magnet dc motor is controlled by a full bridge converter. PI controller is used to control the operation of motor. The block diagram consist of diode bridge rectifier, dc -dc full bridge converter, PMDC motor and a PI controller [1].

Rectifier: Here bridge rectifier is used .LC filter is used in the input section with diode bridge rectifier. Here the rectifier is in uncontrolled manner with diode switches. A switch S is connected in series with diode rectifier. It is very cheap and simple. This rectifier converts ac supply to dc power.

Converter: There are six fundamental DC-DC converters in the power electronics literature: buck, boost, buck-boost, Ćuk, Zeta and Sepic. When the DC source is replaced by a three-phase AC source and diode. Six fundamental TPSSCs can be formed. The power factor correction (PFC) of any of these TPSSCs can be done without sensing any input parameter and an additional controller, as it can occur automatically as a function of the converter's natural switching operation. The converter can operate like a DC-DC single-switch converter with a switch duty cycle (D) that can be considered to be fixed throughout the input line cycle. The six fundamental converters can be divided into two main groups: Converters with an inductive input filter (Boost, Ćuk and Sepic), Converters with a capacitive input filter (Buck, Buck-boost and Zeta) The converters with an inductive input filter ensure the input inductor currents (e.g. i_{sle}) rise and fall in every switching cycle whereas the converters with a input capacitive filter ensure the capacitor voltages (e.g. V_{Ca}) rise and fall [2],[4],[5].

*Converters with an Inductive Input Filter:*The single-switch boost converter is a TPSSC with an inductive input filter. The converter operates as follows: The currents in all three input inductors rise whenever the switch (S) is on and fall to zero whenever the switch is off. where i_{slc} is the current of input inductor L_a that rises from zero to a peak value determined by the instantaneous phase A voltage when S is on ($t_{on} = DT_s$). After S is turned off ($t_{off} = T_s[1-D]$), i_{slc} decreases from its peak value to zero and remains at zero until S is turned on again. The input currents are discontinuous and are a train of triangular pulses whose peaks are bounded by a sinusoidal envelope [5]. This allows a nearly sinusoidal average current (current without high frequency ripple) to be achieved in all three phases. Converters are the other two TPSSCs with an inductive input filter and their input currents can be made to be sinusoidal in the same way as the boost converter [9]-[10].

*Converters with a Capacitive Input Filter:*The single-switch buck converter is an example of a fundamental TPSSC with a capacitive input filter. The converter operates as follows: When the switch (S) is off, each of the three input capacitors (C_a, C_b, C_c) are charged to a level that is proportional to the input line-to-line voltage that is placed across it. When S is turned on, each input capacitor is completely discharged and remains at zero until S is turned off again. Where v_{Ca} is the instantaneous voltage of C_a – the input capacitor for phase A - and V_{aclav} is the average value (voltage without the high frequency ripple) of the discontinuous voltage v_{Ca} . An excellent input power factor (PF) can be achieved if the converter is made to operate with discontinuous input capacitor voltages [2].

Doing so ideally causes these voltages to be sinusoidal with high frequency components that are blocked by the input inductors so that the input phase currents are also sinusoidal with few if any high frequency components. This is because the voltage is a train of triangular pulses whose peaks are bounded by a sinusoidal envelope.

TPSSCs with a capacitive input filter. The input capacitor voltages of both these converters can be shaped so that they are discontinuous and bounded by a sinusoidal envelope just like the buck converter. While the input capacitors are being charged and discharged, the output section of the converter operates in the exact same manner as a standard DC-DC buck converter [3],[6]. The peak voltage stress of S in the buck converter equals the line-line voltage of input capacitors. $V_{S,pk} = \sqrt{3}V_{Ca,pk}$, where $V_{Ca,pk}$ is the peak phase voltage of C_a

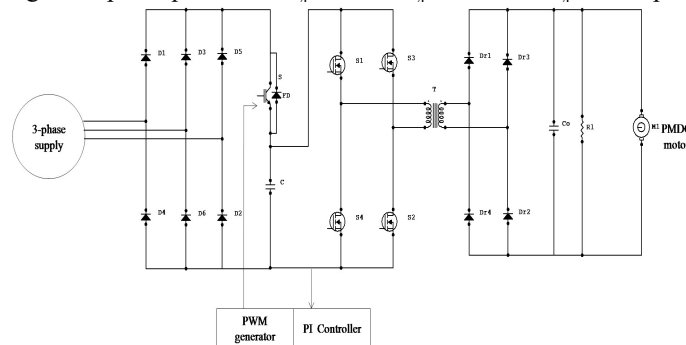

Fig .2 Three-phase AC-DC single switch rectifier and DC-DC full bridge converter

*PI controller:*The controller shown here is a PI controller, where the PI controller get the voltage feedback and it is given as the input .Then the voltage error is compared with the reference voltage and the output of the PI controller is used to control the inverter switches, i.e. as depends on the output of PI .

III. AC-DC SINGLE SWITCH PWM BUCK-TYPE FULL-BRIDGE CONVERTER

The circuit diagram for proposed AC-DC converter is shown in fig.2. here three phase ac supply is given to the diode bridge rectifier. It will convert the ac voltage to dc voltage. A switch S is used to control the voltage across the capacitor. The voltage output across this capacitor is fed to an inverter configured by MOSFETs. Then the high frequency AC voltage goes through transformer stage. Finally this AC voltage convert back to DC voltage by a diode rectifier .The operation of PMDC motor is regulated by controlling the voltage across the capacitor with the help of a PI controller. As depends on the error signals from the PI controller the PWM generator produces respective gate pulse to the Switch S[1].

IV. PRINCIPLE OF OPERATION

Operation can be explained by following two modes

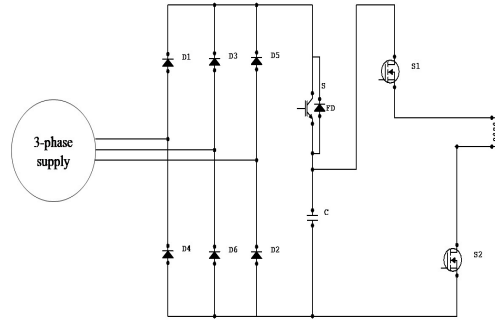

Fig .3 Circuit for mode I operation

Mode 1 operation:

Here the mode of operation is between instant t_0 and t_1 , at instant t_0 MOSFET S1 and S2 are turned on, so the output from the ac-dc single switch rectifier is given to the dc-dc full bridge converter. Then Energy transfer to the PMDC motor connected at the load. In this mode switches S3 and S4 are in off state, at instant t_1 this mode will ends. Circuit for this mode is as shown in figure 3, the remaining part of the proposed converter will works normally [1].

Mode 2 operation:

This mode of operation is in between instant t_2 and t_3 , operation of circuit during this mode is as shown in figure 4, at instant t_2 the switches S3 and S4 are turned on and the output from the ac-dc single switch rectifier is given to the dc-dc full bridge converter through S3 and S4 then Energy is transfer to PMDC motor connected at the load side .in this mode switches S1 and S2 will be in off state. At t_3 this mode will ends and for next subsequent cycle again mode I operation starts with conduction of S1 and S2.

From these two modes of operation explained above we can understand that mode I and mode II operations are depends on switching sequence of

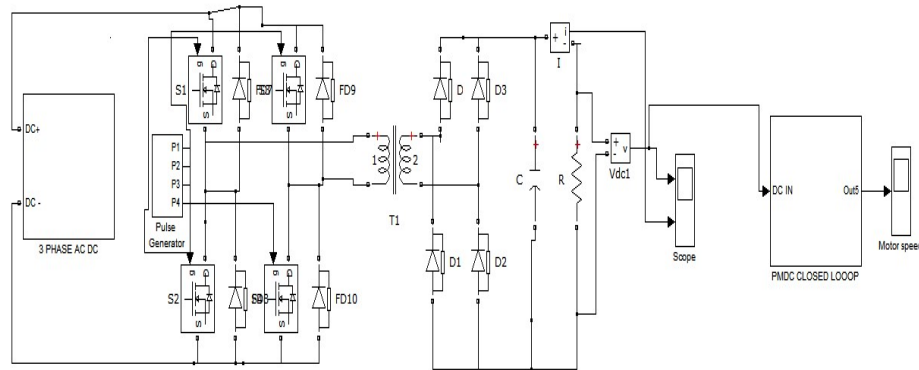

Fig 5.Three-phase AC-DC single switch buck rectifier and dc-dc full bridge converter

S1, S2, S3 and S4, as switch S1 and S2 will operates at first mode and switch S3 and S4 will operates at second mode and effectively transfer the energy to the required PMDC motor .here speed of motor is regulated as a function of voltage appears across the capacitor connected in the same leg of switch S this voltage across capacitor is controlled with the help a PI controller[1]-[4].

V. EXPERIMENTAL RESULTS

The proposed circuit is developed and analyzed with MATLAB software. MATLAB simulation circuit diagram for proposed Three-phase AC-DC single switch buck rectifier and dc-dc full bridge converter is shown in fig 5 Resultant output waveforms after simulation is as given below

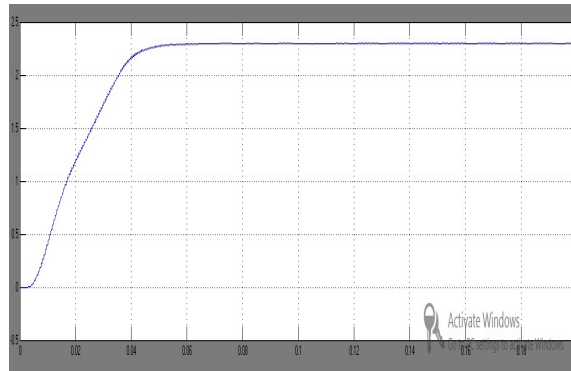

Fig 6 Converter output current waveform

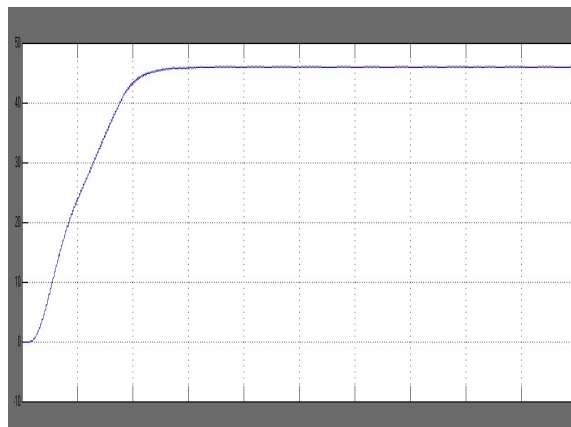

Fig 7. Converter Output Voltage

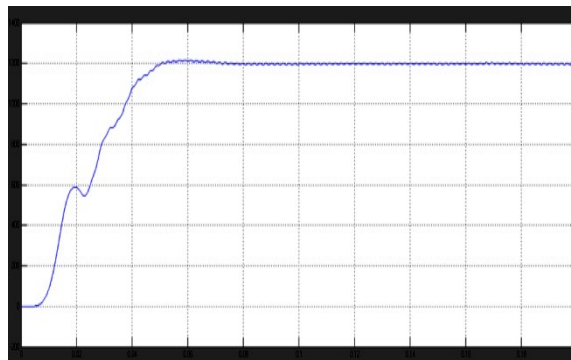

Fig 8 Speed Output

VI. CONCLUSION

This work developed a three phase AC input voltage into an isolated DC output voltage with a reduced number of switches for speed controlling PMDC motor. Most previously proposed three-phase single-switch converters have a boost converter input section. These converters suffer from high input ripple as their input currents are discontinuous with high current peaks, high output ripple and large low-frequency components at the output due to a lack of capacitor filter at the output side. Converters that are based on buck converters do not have these drawbacks as they have inductive-capacitive filtering in their input and output sections and can be implemented with a bulk capacitor at their dc bus. The main objective of this paper has been therefore to examine a three-phase single-switch converter. In this work, the operation of this fundamental full-bridge converter topology and a method of analyzing its steady-state operation were presented with PMDC motor as load. The feasibility of the converter was confirmed with results obtained from a Simulation prototype

REFERENCES

- [1] D.S. Wijeratne and G. Moschopoulos, "Three-Phase Single-Stage AC-DC PWM Buck-Type Full-Bridge Converter: Analysis, Design, and Characteristics". *IEEE Trans. on industrial drives.*, Vol. 60, No 10, October 2013.
- [2] H. Athab, D. Lu, and K. Ramar, "A single-switch ac/dc flyback converter using a CCM/DCM quasi-active power factor correction front-end," *IEEE. Trans. Ind. Electron.*, vol. 59, no. 3, pp. 1517–1526, Mar. 2012.
- [3] H.-L. Cheng, Y.-C. Hsieh, and C.-S. Lin, "A novel single-stage high power factor ac/dc converter featuring high circuit efficiency," *IEEE Trans. Ind. Electron.*, vol. 58, no. 2, pp. 524–532, Feb. 2011.
- [4] B. Tamyurek and D. A. Torrey, "A three-phase unity power factor single stage ac-dc converter based on an interleaved flyback topology," *IEEE Trans. Power Electron.*, vol. 26, no. 1, pp. 308–318, Jan. 2011.
- [5] P. J. Grbović, P. Delarue, and P. Le Moigne, "A novel three-phase diode boost rectifier using hybrid half-dc-bus-voltage rated boost converter," *IEEE. Trans. Ind. Electron.*, vol. 58, no. 4, pp. 1316–1329, Apr. 2011.
- [6] T. T. L. Pham, F. Richardeau, and G. Gateau, "Fault diagnosis and PDPWM reconfiguration of a 5-level double-boost PFC with fault-tolerant capability," in *Proc. IEEE IECON*, Nov. 7–10, 2010.
- [7] GovindarajThangavel, "Finite Element Analysis of the Direct Drive PMLM" In book: Finite Element Analysis - New Trends and Developments, Chapter: 6, InTech online Publisher, 10 Oct 2012.
- [8] H.-Y. Tsai, T.-H. Hsia, and D. Chen, "A family of zero-voltage-transition bridgeless power-factor-correction circuits with a zero-current-switching auxiliary switch," *IEEE. Trans. Ind. Electron.*, vol. 58, no. 5, pp. 1848–1855, May 2011.
- [9] M. Milanovic and P. Slibar, "IDF-correction-based PWM algorithm for three-phase ac-dc buck converter," *IEEE. Trans. Ind. Electron.*, vol. 58, no. 8, pp. 3308–3316, Aug. 2011.
- [10] Y. Jang, D. L. Dillman, and M. M. Jovanović, "Three-phase isolated high power factor rectifier using soft-switching two-switched forward converter," in *Proc. IEEE APEC*,
- [11] G. Neelakrishnan, K. Anandhakumar, A. Prathap, S. Prakash "Performance Estimation of cascaded h-bridge MLI for HEV using SVPWM" *SurajPunj Journal for Multidisciplinary Research*, 2021, Volume 11, Issue 4, pp:750-756
- [12] G. Neelakrishnan, S.N.Pruthika, P.T.Shalini, S.Soniya, "Performance Investigation of T-Source Inverter fed with Solar Cell" *SurajPunj Journal for Multidisciplinary Research*, 2021, Volume 11, Issue 4, pp:744-749
- [13] C.Nagarajan and M.Madheswaran - 'Experimental verification and stability state space analysis of CLL-T Series Parallel Resonant Converter' - *Journal of ELECTRICAL ENGINEERING*, Vol.63 (6), pp.365-372, Dec.2012.
- [14] C.Nagarajan and M.Madheswaran - 'Performance Analysis of LCL-T Resonant Converter with Fuzzy/PID Using State Space Analysis' - Springer, *Electrical Engineering*, Vol.93 (3), pp.167-178, September 2011.
- [15] C.Nagarajan and M.Madheswaran - 'Stability Analysis of Series Parallel Resonant Converter with Fuzzy Logic Controller Using State Space Techniques' - Taylor & Francis, *Electric Power Components and Systems*, Vol.39 (8), pp.780-793, May 2011.
- [16] Nagarajan and M.Madheswaran - 'Experimental Study and steady state stability analysis of CLL-T Series Parallel Resonant Converter with Fuzzy controller using State Space Analysis' - *Iranian Journal of Electrical & Electronic Engineering*, Vol.8 (3), pp.259-267, September 2012..