

Solar Resonant Converter Fed PMDC Motor

Dr C.Nagarajan,
*Head of Department,
Department of EEE,
Muthayammal College of Engineering, Rasipuram.*

Mr D. Kalidass,
*Assistant professor,
Department of EEE,
Muthayammal College of Engineering, Rasipuram.*

K.Kaviya,
*Student, Department of EEE,
Muthayammal College of Engineering, Rasipuram.*

G.Renukadevi,
*Student, Department of EEE,
Muthayammal College of Engineering, Rasipuram.*

S.Sudhagar,
*Student, Department of EEE,
Muthayammal College of Engineering, Rasipuram.*

Abstract: This project proposes a photovoltaic powered DC-DC resonant converter. The proposed resonant converter provides very efficient power conversion due to low electromagnetic interference, low switching losses and light weight of components. The proposed topology consist of a PV cell as a DC input source, two capacitors at input side acts as a voltage divider, a half bridge inductor-capacitor-inductor (L-C-L) parallel resonant inverter and a bridge rectifier, the output stage of proposed resonant converter is filtered by a low pass filter . The PV cell at the input will compromise with current energy demand. Converter output voltage is effectively utilized for driving a PMDC motor; here speed of motor is regulated by controlling the output voltage of converter with the help of a PI controller.

Index terms- LCL resonant inverter, Zero Voltage Switching, Photovoltaic (PV) system. PMDC motor

I. INTRODUCTION

With the current global energy crisis, the focus is on efficiency and electronic products are facing the daunting challenge of delivering high performance, while consuming less power. As a result of this crisis, various agencies around the world have or are looking to increase their efficiency standards for numerous products in their respective specifications. It will be difficult to meet these efficiency specifications with conventional hard switched converters. In the normal DC to DC power converters, semiconductor switches are the major components .Pulse width modulation PWM is the simplest way to control the power semiconductor switches, here control over power is takes place by Interrupting current or voltage through switch action control of duty cycle. But here the switches needs to with stand high stresses, this will leads to switching power losses. Presence of current driven transformer in the circuit will provide some more losses.

The design of the optimized integrated transformer requires specific competence. A higher switching frequency implies smaller and lighter inductors, capacitors, as well as filter components of these converters. Electromagnetic interference (EMI) and switching losses increases with an increase in switching frequency, this will cause decrease in efficiency and overall performance of DC-DC converter becomes poor. To solve these problems power supply designers will need to consider soft switching topologies to improve the efficiency as well as to allow for higher frequency operation[11]-[16].One such topology is the LLC resonant converter. In the DC-DC converters efficiency is very important during the energy conversion. But in existing converters, presence of large number of components and switching losses made it less efficient .These drawbacks can be overcome by the proposed topology, here the soft switching DC-DC converter is constructed by cascading a resonant dc to alternating current (ac) inverter and a bridge rectifier [1]-[7].The dc input is first converted into ac power by the resonant inverter, the ac power then

converted back into dc power by the bridge rectifier[8]. Here the resonant circuit is based on the parallel loaded resonant converter, hence low switching losses, low stresses and low noise characteristics; the parallel loaded-resonant converter can control the output voltage at no load by running at a frequency above resonance. The parallel loaded-resonant converter contains an inductive output filter, to reducing the conduction losses and the ripple voltage of the converter[1]–[7]. Here a higher switching frequency implies smaller and lighter inductor, capacitors, as well as filter components of the converter. The soft switching techniques used here will helps to avoid EMI and switching losses during high frequency operation. The proposed system is inherently short circuit protected, so well suited for efficient conversion of DC-DC. The system can be effectively utilized for driving a PMDC motor; apart from this nowa days resonant converters are most commonly used in power electronic circuits because it is inexpensive and robust. Among the many advantages that resonant power conversion has over conventionally adopted pulse-width modulation include a low electromagnetic interference, low switching losses, small volume, and light weight of components due to a high switching frequency, high efficiency, and low reverse recovery losses in diodes owing to a low di/dt at switching instant [1]–[7], resonant converter is widely used for applications of power electronic productions such as switching power supplies, battery chargers, uninterruptible power systems, renewable energy generation systems, and telecom power supplies.

As we know that fossil fuels are rapidly decreasing and their combustion will results global warming, there should be a better replacement for this traditional fuels with renewable energy resources. Among many renewable energy resources Photovoltaic (PV) energy is most popular due to its inherent properties like noiseless, nonradioactive, pollution-free, and inexhaustible[3]. So here proposed system used PV cell as input DC source PMDC motor finds more and more applications in current world industries and toy manufacturing fields due to its small size, lower manufacturing cost and higher efficiency. Here in this project the converter output voltage is effectively utilized to drive a PMDC motor, the speed of PMDC motor is regulated by controlling the output voltage of converter with the help of a PI controller.

II. PV CELL CHARAECTERISICS

Photovoltaic cell is basically a PN – junction semiconductor, which absorbs photons from sunlight and directly generates electro motive force (EMF) as the result of ionization of radiation. The fig 1 shows equivalent circuit for a PV cell [3], [16].

III. BLOCK DIAGRAM DESCRIPTION

In the fig.2.1the permanent magnet dc motor is controlled by the resonant converter; where the switching pulse to the inverter is given according to the PI controller output .The block diagram consist of input dc source, resonant inverter with bridge rectifier, a PMDC motor and a PI controller.

As we knowcurrent global energy crisis is very high, so we have to go with renewable energy. In the block diagram used a PV cell as DC input source. PHOTOVOLTAIC (PV) solar energy is one of the green energy sources which can play an important role in reducing greenhouse gas emissions the storage of fossil fuel and global warming, among various renewable energy sources. This PV cell provides required amount of dc supply to the converter [3].

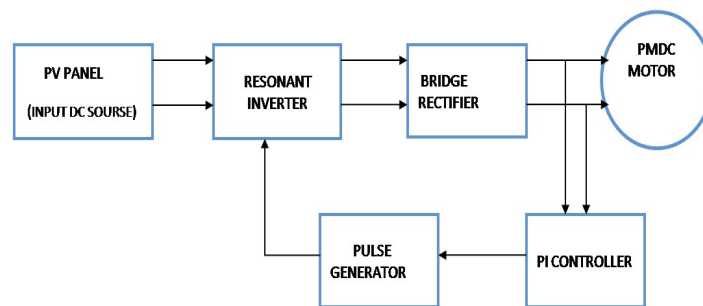

Fig. 2. Block diagram for proposed solar resonant converter fed PMDC motor

In this system after dc input source shown one inverter block, here we used resonant inverter; this block is the key part of the system, as it consists of two power electronic switches with a LLC resonant circuit. Soft switching scheme (ZVS) and high switching frequency made the system simple and compact with small size of components like capacitor, inductor. With respect to other topologies, with the attributes described above, LLC supplies have reduced dimensions with a notable reduction in EMI/EMC issues. This type of inverter produces an approximately sinusoidal waveform at a high output frequency ranging from 20 kHz to 100 kHz, and is commonly used in relatively fixed output applications, for example induction heating, sonar transmitters, fluorescent lamps or ultrasonic generators. Due to the high switching frequency, the size of the resonating components is small. Generally three types of resonant converters are present they are series and parallel resonant converters and series parallel type [13], [14], [1].

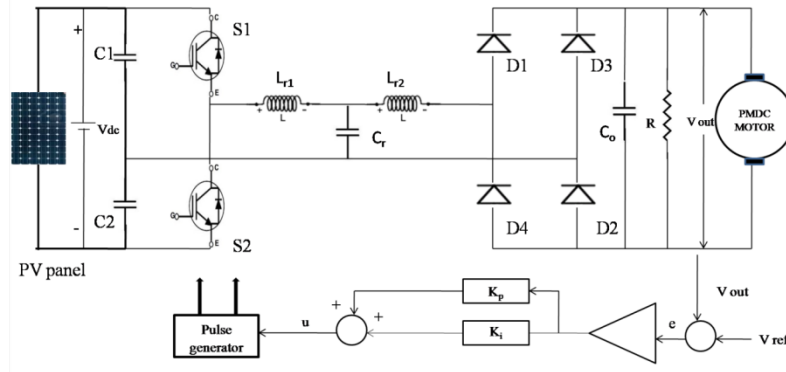

Fig.3. Circuit diagram for solar resonant converter fed PMDC motor

Magnets instead of salient pole wound field structure. The permanent magnets of the PMDC motor are supported by a cylindrical steel stator which also serves as a return path for the magnetic flux. The rotor serves as an armature[17]. It has winding slots, commutator segments and brushes as in conventional dc machines. Permanent Magnet DC motors are useful in a range of applications, from battery powered de- vices like wheelchairs and power tools, to conveyors and door openers, welding equipment, X-ray and topographic systems, and pumping equipment, to name a few. They are frequently the best solution to motion control and power transmission applications where compact size, wide operating speed range, ability to adapt to a range of power sources or the safety considerations of low volt- age are important. Their ability to produce high torque at low speed makes them suitable substitutes for gear motors in many applications. Because of their linear speed-torque curve, they particularly suit adjustable speed and servo control applications where the motor will operate at less than 5000 rpm inside these motors, permanent magnets bonded to a flux- re- turn ring replace the stator field windings found in shunt motors. A wound armature and mechanical brush commutation system complete the motor. The permanent magnets supply the surrounding field flux, eliminating the need for external field current. This design yields a smaller, lighter, and energy efficient motor. In industries 3 phase permanent magnet motors are also used for high speed application

Advantages of PMDC motor:

In very small ratings, use of permanent magnet excitation results in lower manufacturing cost

In many cases a PMDC motor is smaller in size than a wound field dc motor of equal power ratings since field excitation current is not required, the efficiency of these motors is generally higher than that of the wound field motors. Low voltage PMDC motors produce less air noise

PI controller: The controller shown here is a PI controller, the PI controller get the voltage feedback and it is taken as input, this is compared with the reference voltage set by the operator and error signals are generated[2], according to this error signals from PI controller the pulse generator produces the gate pulse for inverter switches, i.e. as depends on the output of PI controller the gate pulse to the inverter switches are produced. PI controller will eliminate forced oscillations and steady state error resulting in operation of on-off controller and P controller respectively. However, introducing integral mode has a negative effect on speed of the response and overall stability of the system. Thus, PI controller will not increase the speed of response. It can be expected since PI controller does not have means to predict what will happen with the error in near future. This problem can be solved by introducing derivative mode which has ability to predict what will happen with the error in near future and thus to decrease a reaction time of the controller.

III. CIRCUIT DIAGRAM DESCRIPTION

Here Fig 3 shows the proposed Solar resonant converter for DC-DC conversion application, the output from the converter is effectively utilized for driving a PMDC motor, the speed of PMDC motor is regulated by controlling the output voltage of converter with the help of a PI controller

In the circuit shown first part is a solar PV cell, its characteristics are already described. After input supply two capacitors C_1, C_2 are shown, which are chosen large and will helps for splitting the input voltage, the resonant inverter shown here is formed by two IGBT switches along with resonant tank. The resonant tank consist of inductors L_{r1}, L_{r2} and C_r . After this resonant inverter a bridge rectifier shown is configured by four diodes. Here the PMDC motor is connected across the bridge rectifier via low-pass filter capacitor C_o . For simplicity the power semiconductor switches can be represented as pair of bi directional switches, each pair consist of one power switch and a anti parallel diode. This bidirectional topology will operate at 50% duty ration for a switching period T. Since the switching frequency of IGBT switches are adjustable the converter output voltage/current can be easily determined as it is directly depends the impedance characteristics of L-C-L resonant tank[7]. A large filtering capacitance C_o is used to reduce the loading effect of the output circuit and to maintain constant voltage. Hence the voltage across the bridge rectifier has constant amplitude $+V_o$ and $-V_o$ respectively, depends on whether the current $I_{L_{r2}}$ is positive or

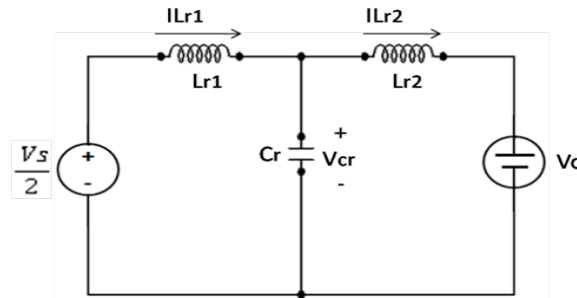

Fig. 4. Equivalent circuit for the proposed converter

Negative. Frequency of his voltage waveform is the same as that of the switching frequency From the above observation the proposed system can be represented by an equivalent circuit (2) as shown in fig 4

IV. PRICIPLE OF OPERATION

The circuit is always operates above resonance, as the switches are operates with soft switching technique. Hence the freewheeling diodes does not required to have fast recovery characteristics.

During +ve half cycle of the current through the inductor L_{r1} , the power is fed to motor through D1 and D2. In -ve half cycle of the current through the inductor L_{r1} , the power is fed to the motor through diodes D3 and D4. Here mainly four modes of operation are present , to analyse that let us consider the equivalent circuit as shown in fig3 ,since the output voltage is assumed to be a constant voltage , then the input voltage of the bridge rectifier V_b is V_o when $I_{L_{r2}}$ is positive and $V_b = -V_o$ when $I_{L_{r2}}$ is negative. The proposed DC to DC resonant converter with a bridge rectifier stage is analysed by considering the fundamental frequency of the Fourier series for the voltage and current. The error due to this approximation is small when the circuit is operates above resonant frequency [7].

Output voltage of the bridge rectifier described by Fourier series is given as

$$V_b(t) = \sum_{n=1,3,5}^{\infty} \frac{4V_o}{n\pi} \sin(n\omega t) \dots \dots (5)$$

Then fundamental components of voltage V_b is

$$V_b(t) = \frac{4V_o}{\pi} \sin(\omega t) \dots \dots \dots (4)$$

The current at the output of the bridge rectifier is the full wave rectifier form of inductor current I_{Lr2} , therefore the average of the rectified inductor current (I_{Lr2}) equals output load current I_o . If inductor current I_{Lr2} is assumed as a sine wave of amplitude I_{LM1} , the average value of output current I_o is

$$I_o = 2 I_{LM1} / \pi \dots \dots (5)$$

Fundamental component of input current is

$$I_{LM1} = \pi I_o / 2 \dots \dots (6)$$

The proposed resonant converter can be simplified as shown below in fig 5

Here equivalent resonant capacitor is C_{eq}

$$C_{eq} = \frac{(wR_eC_r)^2 + (wL_r2C_r - 1)^2}{W^4L_r2C_r + W^2R^2C_r - W^2L_r2}$$

Equivalent resistance is R_{eq}

$$R_{eq} = \frac{R_e}{(WR_eC_r)^2 + (WL_r2C_r - 1)^2}$$

According to the output requirement the duty ratio of inverter switches are selected, but the inductor in the resonant tank should be selected to with stand the current ratings. So by the appropriate selection of inductance and duty ration of inverter switches required output condition can be easily achieved, here the IGBT switches with ZVS technique gives good performance with high reliability[4].

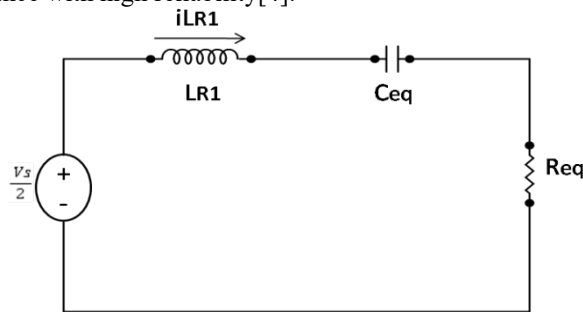

Fig. 5. Simplified equivalent circuit diagram

Steady-state operations of the proposed converter in a switching period can be divided into four modes[7].

Mode 1 operation:

Fig 6 shows the equivalent circuit for this mode of operation of proposed resonant converter, here operation is in between instant t_0 and t_1 . The resonant tank voltage is periodically switching between $+ V_s/2$ and $- V_s/2$, so a square wave voltage is selected across the input terminals

Let us assume output voltage is constant voltage V_o , the input to the diode rectifier becomes positive V_o when current through L_{r2} is positive and input to the rectifier becomes negative V_o when current I_{Lr2} is negative. The IGBT switch S_1 is turned on at instant t_0 , at that time current through L_{r1} is negative and flows through FD1 .at instant t_1 current I_{L1} reverses and naturally commutates from freewheeling diode FD1 to IGBT switch S_1 .

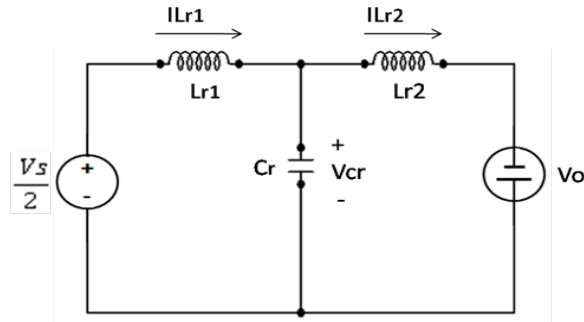

Fig. 6. Equivalent circuit for Mode I.

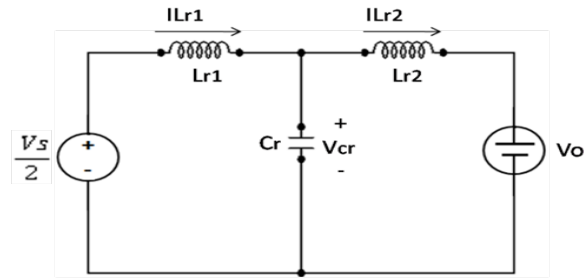

Fig. 7. Equivalent circuit for Mode II

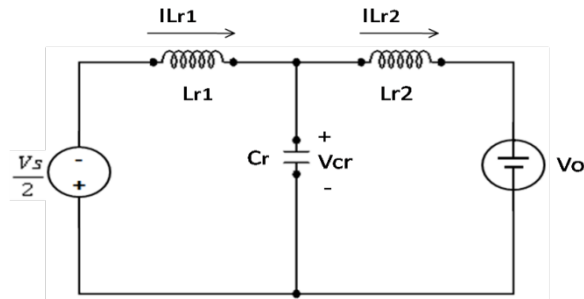

Fig.8. Equivalent circuit for Mode III.

Mode 2 operation:

For this mode of operation consider an equivalent circuit of proposed converter as shown in fig .7, here operation is between time period t_1 and t_2 . at t_1 the current through L_{r1} is resonates from negative values to zero. At t_2 switch S_1 is forced to turn off, this will force the positive current to flow through bottom freewheeling diode FD2. Here resonant current flows through the power switches are going quickly to zero with the help of positive dc input voltage applied across the resonant tank.

Mode 3 operation:

Equivalent circuit for this mode is shown fig 8, Operation is between time period t_3 and t_4 :this mode starts at instant t_3 , before starting a turn off gate signal is fed to switch S_1 , this will results the natural commutation of inductor current from switch S_1 to freewheeling diode FD1 , then mode 3 starts with diode D2 turned on ,a resonant stage is created between L_{r1}, L_{r2} and C_r , hence these three components

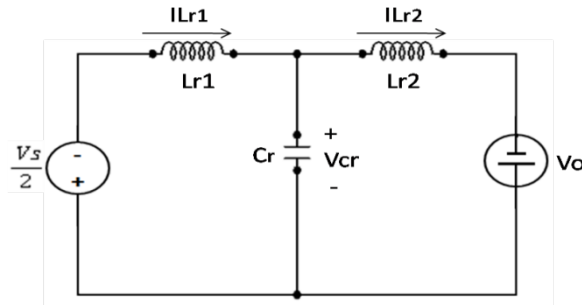

Fig. 9. Equivalent circuit for Mode IV.

get resonated .This mode ends with I_{Lr2} reaches zero at instant t_4 .

Mode 4 operation:

Equivalent circuit for this mode is as shown in fig 9, operation is between time period t_4 and t_5 : at t_4 diodes D1 and D2 are turned on by a positive current I_{Lr2} through inductor L_{r2} .

At instant t_5 D1 and D2 are turned off When inductor current I_{Lr2} changes it's direction, this gives the end of Mode IV. By giving excitation to switch S1 again the operation returns to mode I in the subsequent cycle. During the positive half-cycle of the inductor current I_{Lr2} , the power is fed to the motor through diodes D1 and D2. During the negative half-cycle of the inductor current, the power is fed to the load through diodes D3 and D4.

IV. EXPERIMENTAL RESULTS

The proposed circuit is developed and analyzed with MATLAB software. for analysis DC voltage from PV system is considered as 24 volt .

Here for analysis selected one industrial Battery Operated PMDC motor. These are available in operating voltage from 12 V to 180 V DC. Speed range is 1000 to 4000 rpm and power range is 40W to 140W. These types of motors are well suited for home appliances fans. MATLAB simulation circuit diagram is shown in fig 10, for analysis the converter output voltage is controlled to 12 volts with the help of PI controller.

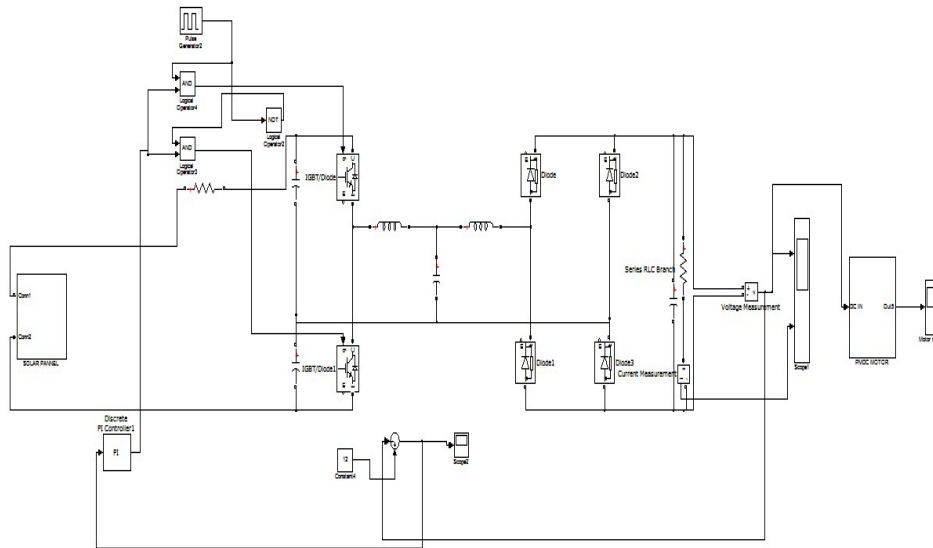

Fig. 10. Simulation circuit for proposed solar resonant converter fed PMDC motor

Fig. 11 shown the input 24 volt DC given to the converter input side, the capacitor C_1 and C_2 splits this and fed to switches S_1 and S_2 , after half bridge inverter stage a square wave voltage is obtained this is shown in Fig. 12

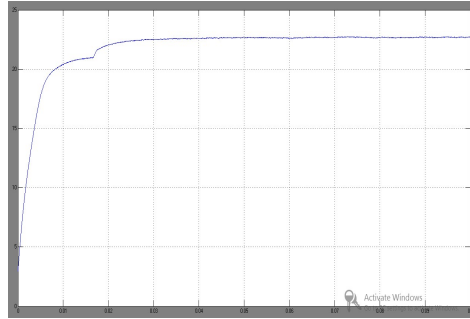

Fig. 11. 24volt DC from PV cell

Since the resonant tank forces the sinusoidal current, only fundamental part of input is fed to rectifier stage, output obtained from resonant tank is a pure ac voltage and is shown in Fig 13

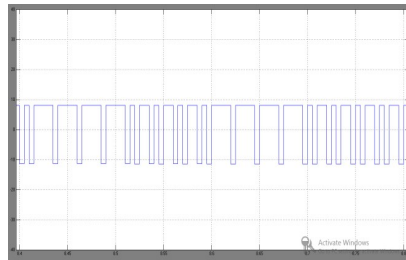

Fig. 12.Voltage after inversion

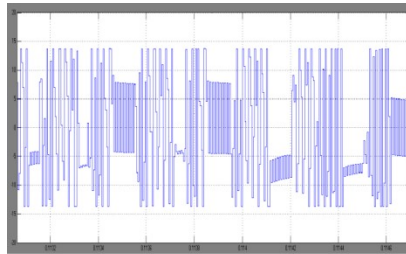

Fig. 13. Voltage out from resonant tank

The ac voltage from resonant tank is rectified by uncontrolled bridge rectifier and a dc output is obtained this contains large ripples , so low pass filter is used to reduce these ripples , 12 volt dc comes out after filtering is shown in Fig 14

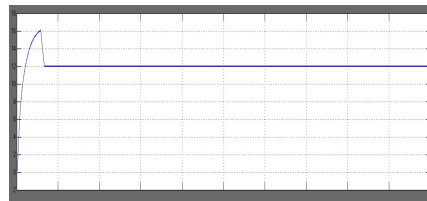

Fig. 14.Converter Output voltage

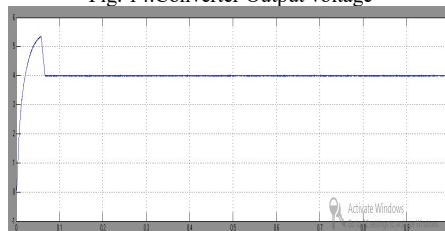

Fig. 15. Converter Output current

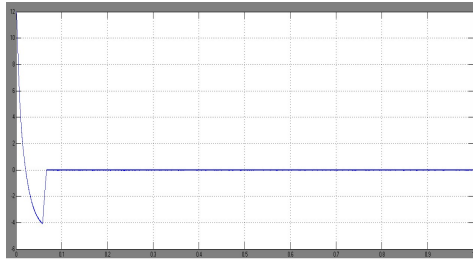

Fig. 16. Error created

As we controlling the converter output voltage to 14 volts the error created is -2 volt shown in fig 16 Gate pulse given to the IGBT switches according to PI controller output is shown in fig 17 and motor speed simulated is given in fig .18

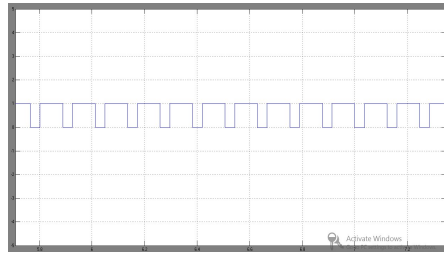

Fig. 17. Gate pulses to the IGBT

V. CONCLUSION

This work developed a solar-resonant converter to DC-DC energy conversion for driving a PMDC motor. This resonant converter structure is simple and less expensive as compared to other converters due to lesser number of components. The developed topology is characterized by reduced switching losses, and higher energy conversion efficiency. Zero voltage switching with IGBT switches gives fast switching with more reliability. Since the switching frequency of IGBT switches are adjustable the converter output voltage/current can be easily obtained as it is directly depends the impedance characteristics of L-C-L resonant tank. Here the proposed solar-resonant converter output voltage is applied to a PMDC motor, speed of PMDC motor is regulated with PI controller by controlling the converter output voltage. The proposed system is analyzed by simulation circuits using MATLAB software and resultant outputs are obtained.

REFERENCES

- [1]. Rui Yang, HongFa Ding, Yun Xu, Lei Yao, and YingMengXiang, "An Analytical Steady-State Model of LCC type Series-Parallel Resonant Converter With Capacitive Output Filter" IEEE trans. power electron, VOL. 29, NO. 1, JANUARY 2014
- [2]. Ahmed A. Aboushady, Khaled H. Ahmed, Stephen J. Finney, and Barry W. Williams "Linearized Large Signal Modeling, Analysis, and Control Design of Phase-Controlled Series-Parallel Resonant Converters Using State Feedback" IEEE trans. power electron, VOL. 28, NO. 8, AUGUST 2013
- [3]. Chien-Hsuan Chang, En-Chin Chang, and Hung-Liang Cheng, "A high-efficiency solar array simulator implemented by an LLC resonant DC-DC converter," IEEE Trans. PowerElectron, VOL. 28, NO. 6, JUNE 2013
- [4]. Thiago B. Senior, Jonas Mühlethaler, JörgenLinnér, Per Ranstad, and Johann W. Kolar, "Automated Design of a High-Power High-Frequency LCC Resonant Converter for Electrostatic Precipitators" IEEE trans. power electron VOL. 60, NO. 11, NOVEMBER 2013
- [5]. ing-Chun Chuang, Yu-Lung Ke, Hung-Shiang Chuang, and Jung-Tai Chen "A Novel Loaded-Resonant Converter for the Application of DC-to-DC Energy Conversions" IEEE trans. industry applications, VOL. 48, NO. 2, MARCH/APRIL 2012
- [6]. Il-Oun Lee, and Gun-Woo Moon, "Analysis and design of a three-level LLC series resonant converter for high and wide input voltage applications," IEEE Trans. PowerElectron, VOL. 27, NO. 6, JUNE 2012
- [7]. R. Beiranvand, B. Rashidian, M. R. Zolghadri, and S. M. H. Alavi, "A design procedure for optimizing the LLC resonant converter as a wide output range voltage source," IEEE Trans. Power Electron., vol. 27, no. 8, pp. 3749–3763, Aug. 2012
- [8]. GovindarajThangavel, "Finite Element Analysis of the Direct Drive PMLM" In book: Finite Element Analysis - New Trends and Developments, Chapter: 6, InTech online Publisher, 10 Oct 2012.
- [9]. Y. M. Lai, S.-C. Tan, and Y. M. Tsang, "Wireless control of load current sharing information for parallel-connected DC/DC power converters," IET Power Electron., vol. 2, no. 1, pp. 14–21, Jan. 2009
- [10]. Milan Ilic and DraganMaksimovi "Interleaved zero current transition buck converter,"IEEE Trans. PowerElectron,VOL. 43, NO. 6, NOV/DEC 2007

- [11]. J. P. Lee, B. D. Min, T. J. Kim, D. W. Yoo, and B. K. Lee, "A novel topology for photovoltaic series connected DC/DC converter with high efficiency under wide load range," in Proc. IEEE Power Electron. Spec.Conf., 2007, pp. 152–155.
- [12]. G.Neelakrishnan, K.Anandhakumar, A.Prathap, S.Prakash "Performance Estimation of cascaded h-bridge MLI for HEV using SVPWM" SurajPunj Journal for Multidisciplinary Research, 2021, Volume 11, Issue 4, pp:750-756
- [13]. G.Neelakrishnan, S.N.Pruthika, P.T.Shalini, S.Soniya, "Perfromance Investigation of T-Source Inverter fed with Solar Cell" SurajPunj Journal for Multidisciplinary Research, 2021, Volume 11, Issue 4, pp:744-749
- [14]. Sharaf A.M , Elbakush. E ,Altas I.H "Novel Control Strategies For Photovoltaic Powered PMDC Motor Drives" Electrical Power Conference,IEEE Canada 2007,pp 461 - 466
- [15]. [20] Changrong Liu, Amy Johnson, and Jih-Sheng Lai, "A novel three phase high power soft switched DC/DC converter for low voltage fuel cell applications," IEEE Trans. PowerElectron, vol. 41, no. 6, NOV/DEC 2005
- [16]. C.Nagarajan and M.Madheswaran - 'Experimental verification and stability state space analysis of CLL-T Series Parallel Resonant Converter' - Journal of ELECTRICAL ENGINEERING, Vol.63 (6), pp.365-372, Dec.2012.
- [17]. C.Nagarajan and M.Madheswaran - 'Performance Analysis of LCL-T Resonant Converter with Fuzzy/PID Using State Space Analysis'- Springer, Electrical Engineering, Vol.93 (3), pp.167-178, September 2011.
- [18]. C.Nagarajan and M.Madheswaran - 'Stability Analysis of Series Parallel Resonant Converter with Fuzzy Logic Controller Using State Space Techniques'- Taylor & Francis, Electric Power Components and Systems, Vol.39 (8), pp.780-793, May 2011.
- [19]. Nagarajan and M.Madheswaran - 'Experimental Study and steady state stability analysis of CLL-T Series Parallel Resonant Converter with Fuzzy controller using State Space Analysis'- Iranian Journal of Electrical & Electronic Engineering, Vol.8 (3), pp.259-267, September 2012.