

# Four Switch Three Phase Inverter Fed Induction Motor Based On Fuzzy Controller

Dr C.Nagarajan,  
*Head of Department,  
Department of EEE,  
Muthayammal College of Engineering, Rasipuram.*

S.Nandhakumar,  
*Student, Department of EEE,  
Muthayammal College of Engineering, Rasipuram.*

T.Naveen,  
*Student, Department of EEE,  
Muthayammal College of Engineering, Rasipuram.*

N.Vignesh,  
*Student, Department of EEE,  
Muthayammal College of Engineering, Rasipuram.*

**Abstract-**This paper proposes a torque control strategy for induction motor (IM) drives fed by a four switch three-phase inverter (FSTPI). The introduced strategy is based on the emulation of the operation of the conventional six switch three-phase inverter (SSTPI). This has been achieved thanks to a suitable combination of the four unbalanced voltage vectors intrinsically generated by the FSTPI, leading to the synthesis of the six balanced voltage vectors of the SSTPI. The proposed scheme use the fuzzy logic controller and PI controller to maintain the steady state operation of the Induction motor .Simulation results have revealed that, thanks to the proposed fuzzy control strategy, FSTPI-fed IM drives exhibit interesting performance.

**Index terms-**Balanced voltage vectors, direct torque control (DTC), four-switch/six-switch three-phase inverter (FSTPI/SSTPI), induction motor (IM) drive, vector selection table.

## I. INTRODUCTION

In recent years, direct torque control (DTC) strategies of induction motor (IM) drives have been widely implemented in industrial variable speed applications. Introduced in the middle of the 1980s, the first DTC strategy involves a simple control scheme which makes it possible rapid real-time implementation. Since then, several investigations carried out in order to improve the performance of the original DTC strategy. The major focused features are the uncontrolled switching frequency of the inverter and the high torque ripple resulting from the use of flux and torque hysteresis controllers. Currently and more than two decades of investigation, several DTC strategies have been proposed so far. These could be classified within four major categories: 1) strategies considering variable hysteresis band controllers; 2) strategies with space vector modulation (SVM)-based control of the switching frequency 3) strategies using predictive control schemes and 4) strategies built around intelligent control approaches. Nevertheless, the gained performance is allied to significant increase of implementation schemes.

Commonly, the voltage source inverter (VSI) feeding IM under DTC is the six-switch three-phase inverter (SSTPI). This said, some applications such as electric and hybrid propulsion systems, should be as reliable as possible. Within this requirement, the reconfiguration of the SSTPI into a four- switch three phase inverter (FSTPI), in case of a switch/leg failure, is currently given an increasing attention. These drawbacks of low dynamic and the high ripple of the torque are due to the application of unbalanced voltage vectors to control flux and torque with a subdivision of the *Clarke* plane limited to four sectors.

It has been noted that the drive performance remains relatively low due to the increase of the CPU time which is linked to the complexity of the involved vector selection table. In order to achieve a constant switching frequency and to decrease the torque ripple, many DTC schemes based on SVM, using the FSTPI as a VSI, dedicated to control induction and permanent-magnet synchronous motors have been reported in the literature. These strategies offer high performance in terms of torque ripple reduction allied to the control of the inverter switching losses. However, these performances are compromised by the complexity of their implementation

schemes. This paper proposes a new fuzzy logic to FSTPI fed IM drives. It is based on the emulation of the SSTPI operation with fuzzy controlled PWM. The resulting simplicity of the implementation scheme makes the strategy very attractive in many applications, such as the automotive one.

The DTC strategy is based on the emulation of the operation of the conventional SSTPI. This has been achieved thanks to suitable combinations of the four unbalanced voltage vectors intrinsically generated by the FSTPI, leading to the synthesis of the six balanced voltage vectors yielded by the SSTPI. This approach has been adopted in the design of the vector selection table which is simply addressed by hysteresis controllers, considering a subdivision of the *Clarke* plane into six sectors. This scheme result low dynamic and high ripple of torque, due to the unbalanced control of flux and torque components. The proposed scheme is able to reduce the torque and flux ripple by reducing the switching frequency. PI controller will eliminate forced oscillations and steady state error and control the motor operation by controlling the PWM signals. A fuzzy inference expert controller is introduced. The resulting simplicity of the implementation scheme makes the strategy very attractive in many applications, such as the automotive one.

## II. CIRCUIT DIAGRAM DESCRIPTION

The circuit diagram consists of rectifier section to convert the alternating current into direct current. It is formed with the help of 6 diodes connected across source. Then the DC current fed to the 4 switch inverter which drives the induction motor.

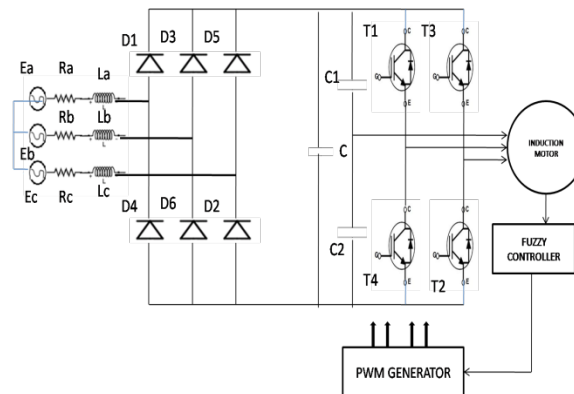

Fig 1 Circuit Diagram for fuzzy controlled induction motor drive

The diodes are connected across the ac supply at the input side. The IGBT switches from T1 to T4 are triggered according to the sequence. The converted dc voltage is given to the induction motor. The inference machine provides the mechanism of triggering rules and implementation. A fuzzy inference machine is proposed based on the rule triggering to make the expert controller work in parallel triggering. Four Switch Three phase inverter Operation:

Over the years induction motor (IM) has been utilized as a workhorse in the industry due to its easy build, high robustness, and generally satisfactory efficiency. By tradition, 6-switch 3-phase inverters have been widely used for variable speed IM drives. The last work on FSTPI for IM drives investigated the performance of a 4-switch, 3-phase inverter fed cost effective induction motor in real time, which has been implemented by vector control. A standard three-phase voltage source inverter utilizes three legs [six-switch three-phase voltage source inverter, with a pair of complementary power switches per phase]. The FSTPI structure generates four active vectors in the plane, instead of six, as generated by the stipe topology. A reduced switch count voltage source inverter [four switch three-phase voltage source inverter uses only two legs, with four switches]. Several articles report on stipe structure regarding inverter performance and switch control. This paper presents a general method to generate pulse width modulated (pwm) signals for control of four-switch, three phase voltage source inverters, even when there are voltage oscillations across the two dc-link capacitors. The method is based on the so called space vector modulation, and includes the scalar version. This permits to implement all alternatives, thus allowing for a fair comparison of the different modulation techniques.

The power inverter has 4 switches, S1, S2, S3 and S4 and a split capacitor. The two phases „a“ and „b“ are connected to the two legs of the inverter, while the third phase c is connected to the Centre point of dc link capacitors, C1 and C2 the value of the capacitances C1 and C2 are equal.  $V_{c1}$  and  $V_{c2}$  are the voltage across the DC link capacitors ( $V_{c1}=V_{c2}$ ). „ $V_{dc}$ “ is the voltage across the capacitor C1 and C2 ( $V_{dc}=V_{c1}+V_{c2}$ ). PWM signals are generated from the Spartan-3 processor by writing VHDL program to control these 4 switches the phase voltage is determined by the duty cycle of the PWM signals. The switching signal parameters namely switching frequency, the

duty ratio and the number of pulses are easily controlled via VHDL programming language. The timing of PWM pulses are generated by using equations a small dead-time is given between switching off the upper switch and switching on the lower switch and vice versa. This ensures that both switches are not conducting when they change states from on to off, or vice versa. For the induction motor drive, the three phase voltage references in a balanced set are given by equation

$$V_{as}^* = V_m \cos \omega t$$

$$V_{bs}^* = V_m \cos \left( \omega t - \frac{2\pi}{3} \right)$$

$$V_{cs}^* = V_m \cos \left( \omega t + \frac{2\pi}{3} \right)$$

$$V_{ac}^* = V_{as}^* - V_{cs}^* = \sqrt{3}V_m \cos \left( \omega t - \frac{\pi}{6} \right)$$

$$V_{bc}^* = V_{bs}^* - V_{cs}^* = \sqrt{3}V_m \cos \left( \omega t - \frac{\pi}{2} \right)$$

$$T_1 = \frac{T_s}{2} + \frac{V_{ac}^*}{V_{dc}} T_s$$

In this paper the scalar modulation scheme is adopted since it is simple and easy. The scalar modulation uses the phase voltages in calculating the switching time. Since the two phases of the induction motor are connected to the inverter legs and the third phase is connected to the neutral point of the dc link, the line-to-line voltage can be used for the PWM instead of the phase voltage. The c phase is connected to the neutral point.

### III. BLOCK DIAGRAM

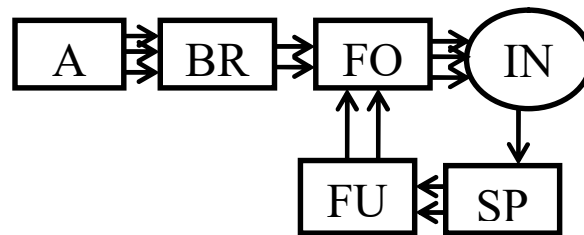

Block Diagram For fuzzy controlled induction motor

#### BLOCK DIAGRAM DESCRIPTION:

The induction motor is controlled by the four switch three phase inverter .The block diagram consist of input supply, driver unit and a control algorithm based pic micro-controller.

#### INPUT SOURCE

As we knowfor the circuit given we are giving a ac supply to the ac-dc rectifier. A dc supply is given to the driver unit and to the control algorithm. The ac output is given to the induction motor after rectification. As we know any invention of latest technology cannot be activated without the source power. So in this fast moving world we deliberately need proper power source which will be apt for a particular requirement. All the electronic components starting from diode to Intel IC’s work with DC supply ranging from +5v to +12v. We are utilizing the same cheapest and commonly available energy source 230V-50Hz and stepping down transformer, rectifier, and filter and voltage regulator.

#### BRIDGE RECTIFIER

In the power supply unit, rectification is normally achieved using a solid state diode. Diode has the property that will let the electron flow easily in one direction at proper biasing condition. As AC is applied to the diode, electrons only flow when the anode and cathode is negative. Reversing the polarity of voltage will not permit electron flow.

A commonly used circuit for supplying large amounts of DC power is the bridge rectifier. A bridge rectifier of four diodes (4\*IN4007) are used to achieve full wave rectification. Two diodes conduct during negative half cycle and the other two during positive half cycle. The DC voltage appearing across the output terminals of the bridge rectifier will be somewhat less than 90% of the applied RMS value. Normally one alteration of the input voltage will reverse the polarities.

Opposite ends of the transformer will therefore always be 180 degree out of phase with each other. For a positive cycle, two diodes are connected to the positive voltage at the top winding and only one diode conducts. At the same

time one of the other two diodes conducts for the negative voltage that is applied from the bottom winding due to the forward bias for that diode In this circuit due to positive half cycle D1 and D2 will conduct to give 10.8V pulsating DC. The DC output has a ripple frequency of 100Hz.

Since each alteration produces a resulting output pulse, frequency=2\*50Hz. The output obtained is not pure DC and therefore filtration has to be done.

*TORQUE ESTIMATOR*

The torque estimator is nothing but the PI controller ,where the PI controller get the speed feedback and it is given as the input .Then the speed error is compared with the reference speed and the output of the PI controller is torque given to the fuzzy logic as a input. The torque is directly controlled by keeping the stator flux constant and stator angle to be changed. Where the torque is estimated by the following equations,

$$T_e = \frac{3P}{2} (\Psi_{ds}^s i_{qs}^s - \Psi_{qs}^s i_{ds}^s) \dots\dots\dots(2.1)$$

$$\theta_e(k) = \tan^{-1} \left( \frac{\Psi_{ds}^s}{\Psi_{qs}^s} \right) \dots\dots\dots(2.2)$$

*FLUX ESTIMATOR*

The flux and the torque ripple is controlled by the fuzzy logic controller in the proposed system. The fuzzy logic controller it get the input from the PI controller as a current component to control the speed .The fuzzy logic output is given to the space vector modulation that is the switching table. The flux is estimated by the equation

$$\Psi_s = \sqrt{(\Psi_{ds}^* )^2 + (\Psi_{qs}^* )^2} \dots\dots\dots(2.3)$$

$$U_s = d/dt(\Psi_s) \dots\dots\dots (2.4)$$

*INDUCTION MOTOR*

The three-phase induction motors are the most widely used electric motors in industry. They run at essentially constant speed from no-load to full-load. However, the speed is frequency dependent and consequently these motors are not easily adapted to speed control. We usually prefer dc. Motors when large speed variations are required. Nevertheless, the 3-phase induction motors are simple, rugged, low-priced, easy to maintain and can be manufactured with characteristics to suit most industrial requirements. Like any electric motor, a 3-phase induction motor has a stator and a rotor. The stator carries a 3-phase winding (called stator winding) while the rotor carries a short-circuited winding (called rotor winding). Only the stator winding is fed from 3-phase supply. The rotor winding derives its voltage and power from the externally energized stator winding through electromagnetic induction and hence the name. The induction motor may be considered to be a transformer with a rotating secondary and it can, therefore, be described as a “transformer-type” ac. machine in which electrical energy is converted into mechanical energy.

IV. FUZZY CONTROLLER

Fuzzy control rule can be considered as the knowledge of an expert in any related field of application. The fuzzy rule is represented by a sequence of the form IF-THEN, leading to algorithms describing what action or output should be taken in terms of the currently observed information, which includes both input and feedback if a closed-loop control system is applied. The law to design or build a set of fuzzy rules is based on a human being’s knowledge or experience, which is dependent on each different actual application. A fuzzy IF-THEN rule associates a condition described using linguistic variables and fuzzy sets to an output or a conclusion. The IF part is mainly used to capture knowledge by using the elastic conditions, and the THEN part can be utilized to give the conclusion or output in linguistic variable form. This IF-THEN rule is widely used by the fuzzy inference system to compute the degree to which the input data matches the condition of a rule.

*Fuzzy Mapping Rules*

Fuzzy mapping rules provide a functional mapping between the input and the output using linguistic variables. The foundation of a fuzzy mapping rule is a fuzzy graph, which describes the relationship between the fuzzy input and the fuzzy output. Sometimes, in real applications, it is very hard to derive a certain relationship between the input and the output, or the relationship between those inputs and outputs are very complicated even when that relationship is developed. Fuzzy mapping rules are a good solution for those situations.

Fuzzy mapping rules work in a similar way to human intuition or insight, and each fuzzy mapping rule only

approximates a limited number of elements of the function, so the entire function should be approximated by a set of fuzzy mapping rules. Still using our air conditioner system as an example, a fuzzy mapping rule can be derived as

IF the temperature is LOW, THEN the heater motor should be rotated FAST.

For most actual applications, the input variables are commonly more than one dimension. For example, in our air conditioner system, the inputs include both current temperature and the change rate of the temperature. The fuzzy control rules should also be extended to allow multiple inputs to be considered to derive the output. Table I is an example of fuzzy control rules applied in our air conditioner system.

The rows and columns represent two inputs, the temperature input and the change rate of the temperature input, and those inputs are related to IF parts in IF-THEN rules. The conclusion or control output can be considered as a third dimensional variable that is located at the cross point of each row (temperature) and each column (change rate of the temperature), and that conclusion is associated with the THEN part in IF-THEN rules. For example, when the current temperature is LOW, and the current change rate of the temperature is also LOW, the heater motor's speed should be FAST to increase the temperature as soon as possible. This can be represented by the IF-THEN rule as

IF the temperature is LOW, and the change rate of the temperature is LOW, THEN the conclusion or output (heater motor speed) should be FAST.

In this air conditioner example, a total of nine rules are developed. For those applications that need high control accuracy, the input and output should be divided into more small segments, and more fuzzy rules should be applied.

<i>T</i>	LOW	MEDIUM	HIGH
LOW	FAST	MEDIUM	MEDIUM
MEDIUM	FAST	SLOW	SLOW
HIGH	MEDIUM	SLOW	SLOW

#### *Fuzzy Implication Rules*

A fuzzy implication rule describes a generalized logic implication relationship between inputs and outputs. The foundation of a fuzzy implication rule is the narrow sense of fuzzy logic. Fuzzy implication rules are related to classical two-valued logic and multiple valued logic. Still using the air conditioner system as an example, the implication is. IF the temperature is LOW, THEN the heater motor should be FAST. Based on this implication and a fact: the temperature is HIGH. The result that the heater motor should slow down or the SLOW can be inferred.

#### *Architectures of Fuzzy Logic Controls:*

A typical fuzzy closed-loop control system, the inputs are error and error rate, which are combined by block *M* to input to the fuzzy inference system.

The lookup table is derived based on the membership function of inputs, the output and the fuzzy control rules. A control gain factor *G* is used to tune the output of the lookup table to obtain different output values. The interpolation block *S* is used to smooth the output element of the lookup table. A feedback signal is obtained from the output of the system. Two lookup tables are developed in this control system, a coarse and a fine table. During the application, the switch between the course and the fine table is under the control of the input error limit. This limit value can be defined by the user based on the real application. Two-set membership functions and control rules are utilized in this system to satisfy the requirement of higher control accuracy.

## V. EXPERIMENTAL RESULTS

The proposed circuit is developed and analyzed with MATLAB software. The results obtained from this simulation as given below.

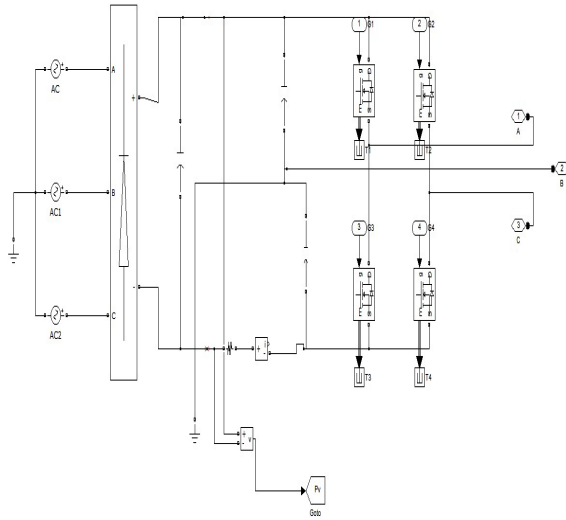

Fig .5 Four switch three phase inverter circuit

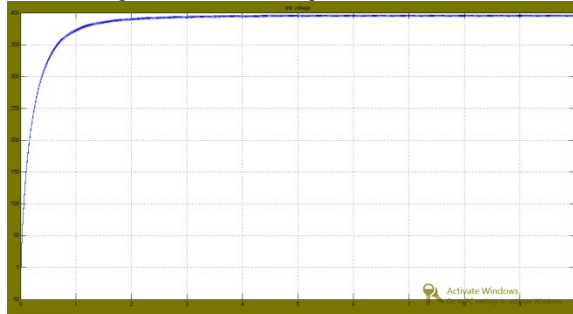

Fig. 6 link output voltage

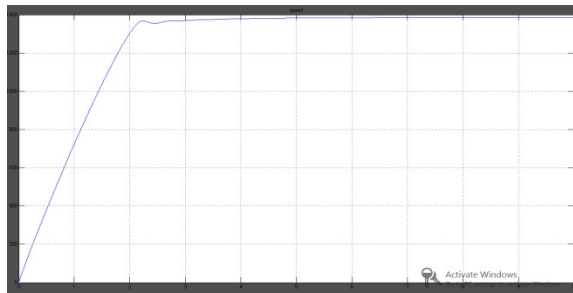

Fig. 7 Motor speed

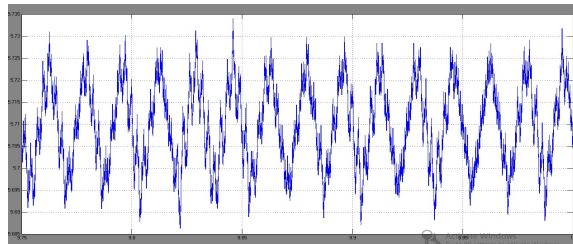

Fig. 8 Motor torque.

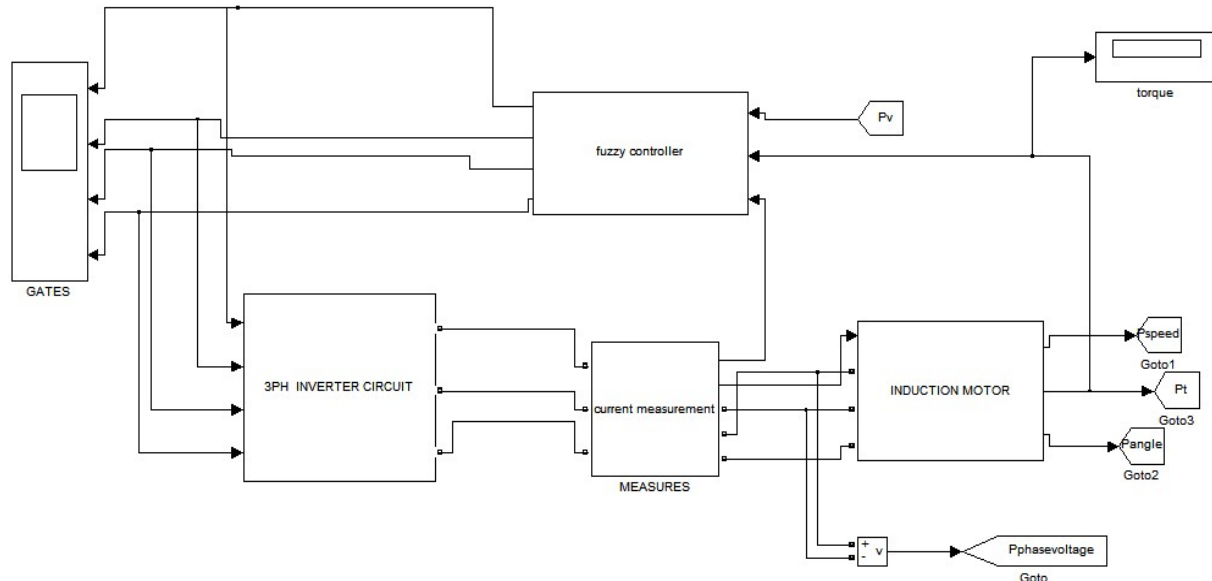

Fig 9 Main Simulation circuit

## VI. CONCLUSION

In this project propose the simplified control of flux and torque of three phase induction motor for industrial applications. The fuzzy controller has been proposed to control the torque in order to avoid the ripples in torque. These strategies allow a direct control of the motor variables through an appropriate selection of the inverter control signals, in order to fulfill the requirements as whether the stator flux and torque need to be increased, decreased, or maintained. The proposed strategy is based on the emulation of the operation of the conventional SSTPI. This has been achieved thanks to suitable combinations of the four unbalanced voltage vectors intrinsically generated by the FSTPI, leading to the synthesis of the six balanced voltage vectors yielded by the SSTPI. Simulation-based investigations of the IM steady-state features have revealed the high performance of the introduced fuzzy controller. This proposed strategy very attractive in many applications, such as the automotive one.

## REFERENCES

- [1] T.Govindaraj, RasilaR, "Development of Fuzzy Logic Controller for DC – DC Buck Converters", IntJ.EnggTechsciVol 2(2), 192-198, 2010 (ISSN 0976-9293)
- [2] Dr.T.Govindaraj, and R.Venkatesh Kumar, "AFLC Based Speed Control of PMSM Drive," International Journal Of Advanced and Innovative Research.ISSN: 2278-7844, Dec-2012, pp 433-439
- [3] Simon.R;Geetha.A, "comparison on the performance of induction motrococontrol using fuzzy and ANFIS controllers".pp.491–495, Mar. 2013
- [4] Naik.N.V;Singh S.P,"A Novel type2 fuzzy logic control of IM drive using space vector PWM," Indian conference,2012Annual IEEE . pp. 1142-1147, 2012.
- [5] \BouhouneK;YaridK;Boucherit M.S, "Fuzzy logic based control of the single phase IM without start capacitor,"POWERENG 2013,4<sup>TH</sup> International conference pp. 747-752.2013
- [6] Kar ,BiranchiNarayan;Mohanty,K.B;Singh.M, "Indirect vector control of Induction Motor using Fuzzy logic control," IEEEIC,2011,10<sup>TH</sup> International conference, pp. 1-4 2011
- [7] Asija.D,"Speed control of IM using Fuzzy-PI controller,"ICMEE.2010. Second International conference pp. V2-460-V2-463, 2010.
- [8] G.Neelakrishnan, K.Anandhakumar, A.Prathap, S.Prakash "Performance Estimation of cascaded h-bridge MLI for HEV using SVPWM" SurajPunj Journal for Multidisciplinary Research, 2021, Volume 11, Issue 4, pp:750-756
- [9] G.Neelakrishnan, S.N.Pruthika, P.T.Shalini, S.Soniya, "Perfromance Investigation of T-Source Inverter fed with Solar Cell" SurajPunj Journal for Multidisciplinary Research, 2021, Volume 11, Issue 4, pp:744-749
- [10] C.Nagarajan and M.Madheswaran - 'Experimental verification and stability state space analysis of CLL-T Series Parallel Resonant Converter' - Journal of ELECTRICAL ENGINEERING, Vol.63 (6), pp.365-372, Dec.2012.
- [11] C.Nagarajan and M.Madheswaran - 'Performance Analysis of LCL-T Resonant Converter with Fuzzy/PID Using State Space Analysis'- Springer, Electrical Engineering, Vol.93 (3), pp.167-178, September 2011.
- [12] C.Nagarajan and M.Madheswaran - 'Stability Analysis of Series Parallel Resonant Converter with Fuzzy Logic Controller Using State Space Techniques'- Taylor & Francis, Electric Power Components and Systems, Vol.39 (8), pp.780-793, May 2011.
- [13] Nagarajan and M.Madheswaran - 'Experimental Study and steady state stability analysis of CLL-T Series Parallel Resonant Converter with Fuzzy controller using State Space Analysis'- Iranian Journal of Electrical & Electronic Engineering, Vol.8 (3), pp.259-267, September 2012.