

# Automatic Monitoring Of Gas Leakage Detection And Gas Booking Alert System For Smart Home Using Iot

M.Kalaiselvi<sup>[1]</sup>, Assistant Professor,

*Department of Computer Science and Engineering*

*Vivekanandha college of technology for women, Tiruchengode, Tamilnadu, India*

N.Nisha Sulthana<sup>[2]</sup>, Assistant Professor,

*Department of Computer Science and Engineering*

*Vivekanandha college of technology for women, Tiruchengode, Tamilnadu, India*

**Abstract**—LPG is widely used for cooking in many countries for economic reasons, for convenience or because it is the preferred fuel source. This paper focuses on the application of the IoT which is used for measuring and displaying the gasoline content present in household LPG cylinder and this is helpful in automatic booking of new LPG cylinder and also detect the gas leakage and start the alarm. Usually the capacity of LPG in Cylinder is not determined, so we are going to display the level of LPG. The level of LPG is measured using load sensor. The output of the sensor is connected with Microcontroller (Atmega8). By use of GSM Module, the information is sent to user by SMS (short messaging service) and also automatic booking is done, when the cylinder gets empty. If no need of the cylinder, then cancel the booking cylinder. Then the gas leakage is detected by gas sensor (MQ-2), then cuts the power supply automatically. By using this, we can detect the current LPG level and it is continuously displayed on the LCD. We can know the validity of LPG usage from the date of initialization. By use of IOT the user is alerted by giving the message to their mobile phone when the LPG level is critically low (below 20%). Automatic booking of new LPG by when the cylinder gets empty then automatically transfer message to the LPG agency for booking cylinder. Then by detecting the gas leakage then information is send the user and fire station.

**Keywords**—GSM module, gas sensor, load sensor, microcontroller Atmega8, internet of things

## I. INTRODUCTION

In our day to day life, LPG cylinder plays a major role. The main application of the LPG is that it is used in the place of chlorofluorocarbon which cause great damage to the ozone layer. Though it's one in all the foremost normally used fuels, it is associate explosive vary of one.8%–9.5% volume of gas in air. It is packed into three classes per the burden of the LPG within the cylinder: social unit, business and Industrial. The social unit class of LPG cylinder contains 14.2 kilo LPG within the cylinder. Similarly, The business and Industrial classes of LPG cylinders contain 19 and 35 kilo of LPG severally. With the rising demand for LPG, users have to be compelled to pre book their LPG cylinder a minimum of a month before the delivery of the new LPG cylinder. Most of the days, users find it difficult to figure out what quantity of LPG is left at intervals the cylinder and this causes tons of bother to them.

In such a state of affairs, associate degree efficient technique to watch the amount of LPG within the cylinder is needed, so the users are tuned into the LPG level at intervals the cylinder. This paper deals with the detection of the gas leakage and cut the power supply automatically, then immediately send the message to the user and fire station. The level of gas in the cylinder and when the gas gets empty transmit message to the lpg agency for automatic booking cylinder and booking information is send to the user. Based on the concept automation of gas booking is done and it has an option of delete button to cancel the booking. The sensor used in this has the high sensitivity and fast response time. The gas sensor detects other gases including cigarette smoke. When the gas is detected the output of the sensor is send to the microcontroller and the buzzer is turned on and when the weight measured using load sensor becomes critically low, the alert is send to the user and the new LPG cylinder is automatic booked. The main application of this proposed system is to overcome the shortcomings such as delay and automatic-booking of the LPG cylinder by the consumers. and if leakage occur cuts the power supply automatically.

## II. LITERATURE SURVEY

T. Machappa, M. Sasikala, and M. V. N. Ambika Prasad exhibited a framework that electrical obstruction increments with increment at intervals the grouping of the gas. The variation of resistance depends on the dopents of the polyaniline, like metal oxides, bimetal oxides (ceramics), etc. conduction, the variation of resistance of the sensing material is either by activity of atmospherically substance on the sensing surface and/or by direct reaction of lattice substance or gap substance with the check gases unit the gas sensing mechanism. Throughout this the gas sensing behavior of polyaniline and polyaniline salt composites unit given.

Fabien Chraim, Yusuf BugraErol, Kris Pister had explained the gas leakage solution for industrial places. Since the leakage of gas in the industries are unknown, the gas sensors are kept around the places where the gas leakage is possible. The information from these sensors are then send to the single system. The two techniques used are fixed instrumentation and mobile sensing. The mobile sensors are placed in the suspective sources and the readings are evaluated in that spot. These readings are then transmitted to the users or workers through wireless connection. But the main drawback is that the localization accuracy is under 5m.

L.P.Deshmukh, T.H.Mujawar, M.S.Kasbe, S.S.Mule, J.Akhtar and N.N.Maldar provides the abstract design so as to watch the outpouring of LPG within the atmosphere.The LabVIEW programming environment is developed to connect large area. The leakage level of a gas concentration is done using the LabVIEW GUI. The nodes and network are configured in this program. The measurements which is taken by the sensor nodes through the coordinator node using USB and ZigBee interface are also captured in this program. When the system detects the gas leakage, it sends a SMS alert to the user and also it activates the alarm. The gas flow emission is also controlled by using the solenoid valve. The output of the system is supervised using the personal computer or laptop.

Kumar Keshamoni and Sabbani Hemanth planned to the sensible Gas Level observance, Booking and Gas outpouring Detector victimization IoT. During this the gas amount within the instrumentation is ceaselessly monitored and it additionally intimates the various branch so as to position the new LPG cylinder. The Radio frequency module is used in order to make the user to use it easily and this module consists of the transmitter and receiver kit. The transmitter is an encoder kit which is fixed in the main board and the receiver is a decoder kit which is fixed in the sub board. In addition to easy usage, it also have the advantage that it gives the same information. The temperature sensor is also used in order to detect the errors which occurs due to the surrounding environment. The main drawback in this system is that the use of processor instead of the controller and moreover there is no security for the user.

## III. EXISTING SYSTEM

The basic principle behind this technique is that the modification in concentration of the LPG is detected associated it activates an audio visual alarm once it exceeds an explicit threshold worth. Further, it sends another alarm message through a radiofrequency (RF) system to the receiver module .The receiver module can be a mobile unit that will be placed anywhere among the premises of the house therefore the alarm area unit typically detected and detected at a distance from the place of gas outflow. The microcontroller reads the voltage from the detector and uses it to calculate modification in concentration. The gas detector is sensitive to many gases and actually gas kind can't be determined. Instead, during this work, it is absolutely was assumed that the gas sensing element has the identical sensitivity for LPG which may be thought-about a sound assumption.

### A. Block diagram

The following figure shows the block diagram of the existing gas leakage system

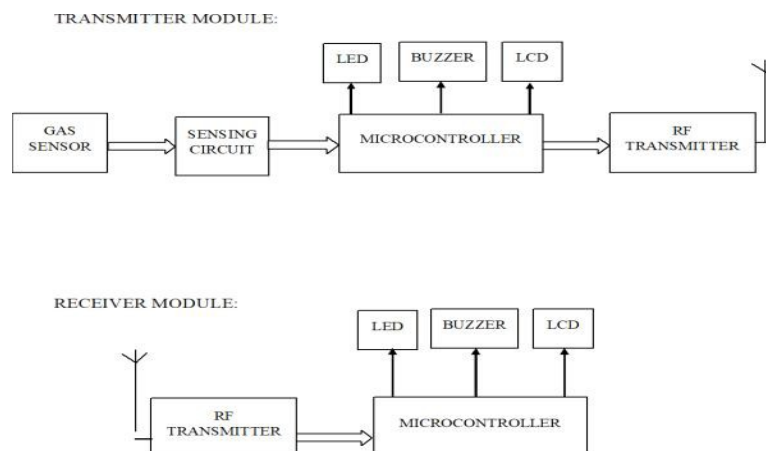

**B. Description**

The following are the components used in this system

**a) Microcontroller:** A microcontroller (MCU for microcontroller unit, or UC for  $\mu$ -controller) may be a tiny laptop on one microcircuit. It is a compact microcircuit designed to control a selected operation in associate embedded system. A typical microcontroller includes a processor, memory and input/output (I/O) peripherals on one chip. It contains one or a lot of CPUs (processor cores) beside memory and programmable input/output peripherals. Program memory within the type of ferroelectric RAM is additionally typically enclosed on chip, furthermore as an tiny low quantity of RAM.

**b) LED:** LED (Light Emitting Diode) is largely a tiny low lightweight emitting device that comes underneath "active" semiconductor electronic elements. The two terminals (anode and cathode) of a semiconductor diode once connected to a voltage offer among the proper polarity, that may manufacture lights of assorted colors, as per the semiconductor substance used among it.

**c) Buzzer:** A buzzer may well be a tool that produces a droning or beeping noise. There area unit several kinds; the foremost basic may well be an electricity buzzer, that's merely a flat piece of electricity material with a pair of electrodes. this kind of buzzer desires some quite generator to drive it. The most drawbacks during this system are

- The existing system is gas leakage detection is done using microcontroller.
- This system contains only few application like gas leakage detection and producing an alarm signal whenever gas leakage is detected.

**IV. PROPOSED SYSTEM**

Gas level detection and automatic booking is designed with various features which is implemented using Microcontroller-Atmega8 and this device will be a single system with multiple applications for LPG consumers. The device monitors the load if the gas level and displays it within the LCD display instantly. It also detects the gas leakage by gas sensor. If gas leakage occur alert to the buzzer and start the alarm and cut the power supply automatically, then immediately send the message to the user and fire station. It can track LPG emptiness if LPG reaches a certain level then it can also transfer message to LPG Agency for automatically ordering the LPG cylinder help of IOT Modules. Then it sends an alert to the registered mobile number by a SMS with the help of GSM module

*Flowchart Automatic gas booking system:*

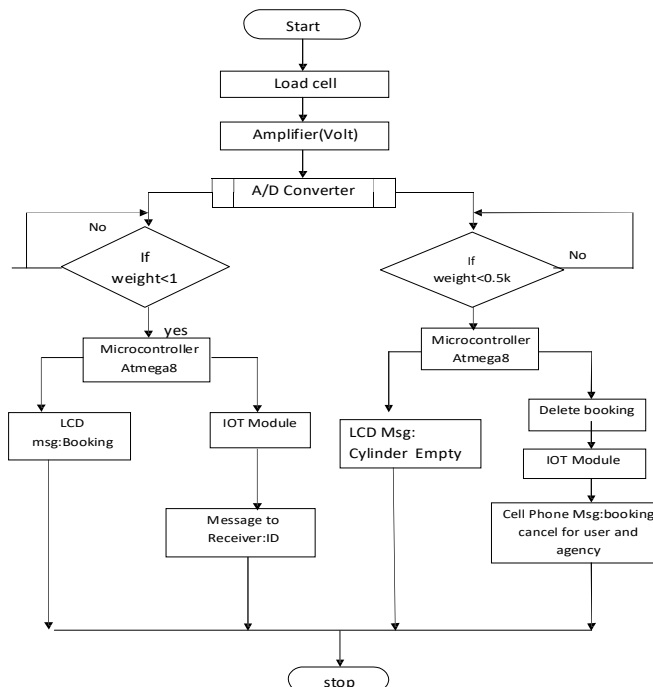

Flow Chart Gas leakage detection diagram

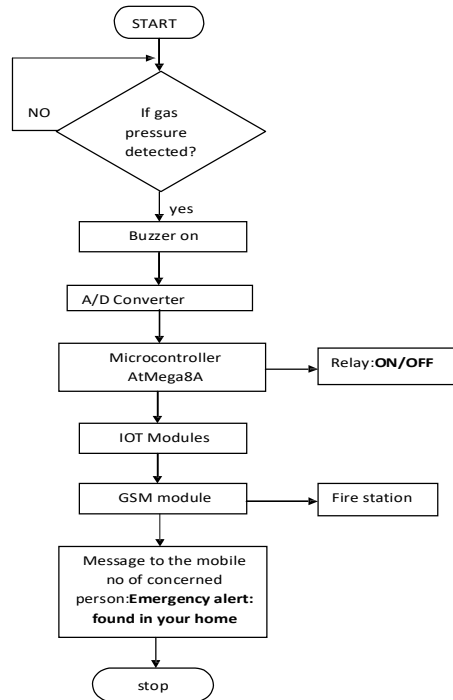

A. Block diagram

Then the following figure shows the block diagram of gas level detection and automatic booking using IoT and also with gas leakage detection. In this the leakage detected is displayed in the LCD and also with SMS alert to user.

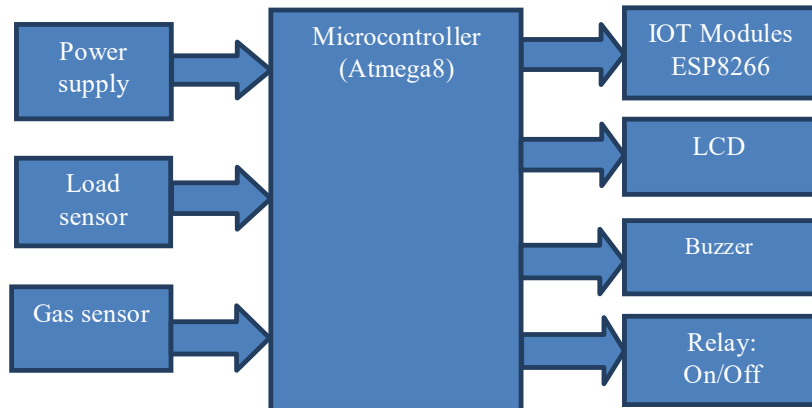

B. Description

This system consists of the following blocks are:

**a) Load sensor:** A load cell is a transducer that measures force, and outputs this force as an electrical signal. The load cells are used since it provides the accurate weight. Strain gauge is used in the most of the load cells for the accurate measurement. The driving voltage if the load is about 5 to 10V. This is used to measure the weight of the cylinder. The accuracy rate is less than 0.1% of the full scale.



**b) Gas Sensor:** Gas Sensor (MQ-2) module is useful for gas leakage detecting. The sensitivity can be adjusted by the potentiometer. Sensitive material of MQ-6 gas sensing element is SnO<sub>2</sub> that with lower physical phenomenon in clean air. The physical phenomenon of the sensing element is high once the flammable gas is detected. The resistance of the sensor is changed when the gaseous element comes in the contact with the sensor. This change causes the change in voltage. This voltage change can be read in the microcontroller. There are different sensitivity values for various gaseous elements.



**c) Microcontroller ATmega8:** The microcontroller supported the ATmega8. There are 14 digital input/output pins. Among this, six pins square wave used as PWM outputs, a sixteen megacycle ceramic resonator, AN ICSP header, a USB association, six analog inputs, an influence jack and a button that contains all the desired support required for microcontroller. this can be then connected to a laptop with a USB cable or with a AC-to-DC adapter or battery to urge started. The AVR is a modified Harvard architecture 8-bit RISC single chip microcontroller which was developed by Atmel in 1996. The AVR was one of the first microcontroller families to use on-chip flash memory for program storage, as opposed to one-time programmable ROM, EPROM, or EEPROM used by other microcontrollers at the time.



**d) LCD:** LCD include some microwatts for show compared to some mill watts. liquid crystal display could be a combination of 2 states of matter, The solid and therefore the liquid. liquid is employed to provide a comprehensible image in liquid crystal display. The liquid crystal display works on the principle of obstruction lightweight. When compared to LED and cathode ray tube, LCD is thinner. Blocking light principle is used for the working of LCD. This is used to display the weight of the gasoline content.

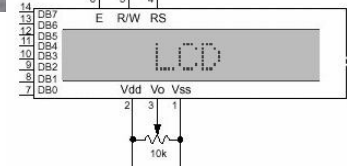

**e) GSM Modem:** GSM could be a mobile communication modem; it's stands for world system for mobile communication (GSM). GSM is employed for transmission mobile voice and knowledge services. They are operated at the 850MHz, 900MHz, 1800MHz and 1900MHz frequency bands that is an open and digital cellular technology. standing indicator can flashes unceasingly whenever the decision arrives otherwise it's left ON. Network junction rectifier can blink each second that indicates that the GSM module is not connected to the mobile network. The LED blink continuously for every 3 seconds, when the connection is established and in off state when the connections aren't established.



**d) IOT Modules:** An **IoT module** is a small electronic device embedded in objects, machines and things that connect to wireless networks and sends and receives data. The **ESP8266** is a low-cost Wi-Fi microchip, with a full TCP/IP stack and microcontroller capability, produced by Espressif Systems in Shanghai, China. This small module allows microcontrollers to connect to a Wi-Fi network. The very low price and the fact that there were very few external components on the module, which suggested that it could eventually be very inexpensive in volume, attracted many hackers to explore the module, the chip, and the software on it, as well as to translate the Chinese documentation. The **ESP8266** is an ESP8266 with 1 MiB of built-in flash, allowing the building of single-chip devices capable of connecting to Wi-Fi.



**V.MODEL DIAGRAM:**

The hardware implementation of the gas level detection and automatic booking system is shown below.

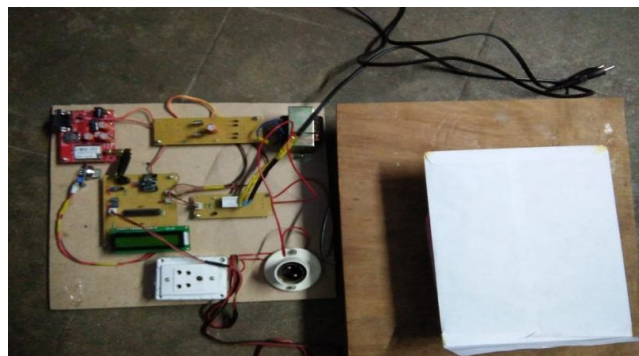

## SAMPLE OUTPUT IN THE USER SIDE:

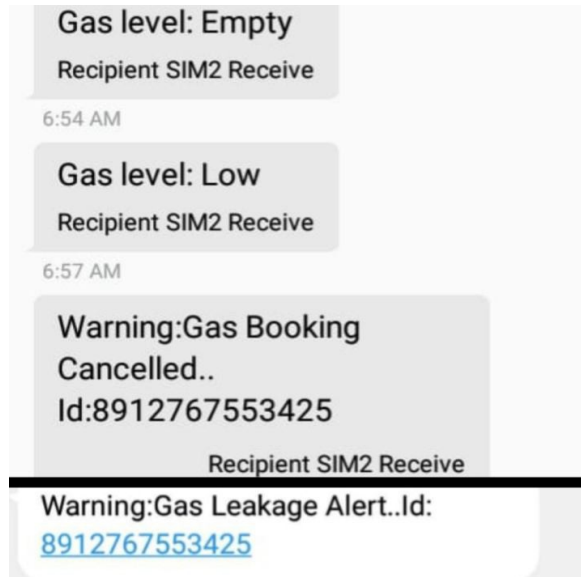

## SAMPLE OUTPUT IN THE BOOKING AGENCY :

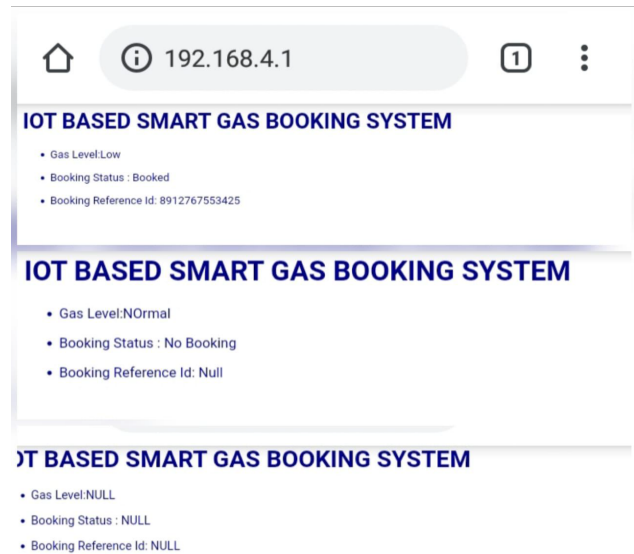

## VI. CONCLUSION

This paper consists of two sections transmitter section and receiver section. In this the automated booking of latest LPG cylinder is enforced. And at last with the application of IoT, new LPG cylinder can be booked by the user and information is send to the user.the users can be aware of their gas level and it also avoids the prior and delay booking of the cylinder. And also the components used here are commercially cheap when compared to other gas detectors. Hence , this concept can also be widely used in the industries according to their requirements.

## REFERENCES

- [1] S., Koushanfar, F., Kosterev, A., Tittel, F., "LaserSPEcks: Laser SPECTroscopic Trace-Gas Sensor Networks - Sensor Integration and Applications", Information Processing in Sensor Networks, 2007. IPSN 2007. 6th International Symposium on, April 2007, p. 226 - 235, ISBN 978-1-59593-638-7
- [2] P. M. Vidya, S. Abinaya, G. G. Rajeswari, and N. Guna, "Automatic lpg leakage detection and hazard prevention for home security," in Proceeding of 5th National Conference on VLSI, Embedded and Communication & Networks on April, vol. 7, 2014.
- [3] N. S. G. B. D. Jolhe and P. A. Potdukhe, "Automatic lpg booking, leakage detection and real time gas measurement monitoring system," International Journal of Engineering Research & Technology (IJERT), vol. 2, April-2013.
- [4] Brush, A. J., Lee, B., Mahajan, R., Agarwal, S., Saroiu, S., & Dixon, C. (2011, May). Home automation in the wild: challenges and opportunities. In Proceedings of the SIGCHI Conference on Human Factors in Computing Systems (pp. 2115-2124).ACM.
- [5] F. Chraim, Y. Erol, and K. Pister, "Wireless gas leak detection and localization," IEEE Trans. Ind. Inf., pp. 1-13, 2015.
- [6] M.S.Kasar, Rupali Dhaygude, Snehal Godse and Sneha Gurgule,"Automatic LPG Gas Booking and Detection System", International Journal of Advanced Research in Electrical, Electronics and Instrumentation Engineering, ISSN 2278-8875, Vol. 5, Issue 3, pp. 1250-1253, March 2016.
- [7] S.Sivajothi Kavitha and S. Senthilkumar, "A Wireless Gas Leakage & Level Detection with Auto Renewal System ", International Journal of Advanced Research in Electrical, Electronics and Instrumentation Engineering, ISSN 2278-8875, Vol. 4, Issue 4, pp. 2095-2100, April 2015.

- [8] M.S.Kasar, Rupali Dhaygude, Snehal Godse and Sneha Gurgule,"Automatic LPG Gas Booking and Detection System", International Journal of Advanced Research in Electrical, Electronics and Instrumentation Engineering, ISSN 2278-8875, Vol. 5, Issue 3, pp. 1250-1253, March 2016.
- [9] G. B. C. V. K. G. S. V. H., B. N. V. Abhishek, P. Bharath, "Automation of lpg cylinder booking and leakage monitoring system," International Journal of Combined Research and Development (IJCRD), pp. 693-695, 2016.
- [10] Ankit Sood, Babalu Sonkar, Atul Ranjan, Ameer Faisal, "Microcontroller Based LPG Gas Leakage Detector Using GSM Module, International Journal of Electrical and Electronics Research, Vol.3, Issue.2, pp: (264-269), Month: April- June 2015.